

94-6

December 2, 1994

**Aircraft Accident  
Investigation Commission  
Ministry of Transport  
Japan**

AIRCRAFT ACCIDENT  
INVESTIGATION REPORT

**(Tentative Translation from Original in Japanese)**

All Nippon Airways  
Boeing 747-400, JA8096  
Tokyo International Airport  
May 2, 1993

## ATTENTION

The English version report has been published and translated by ARAIC to make its reading easier for English speaking people those who are not familiar with Japanese.

Although efforts are made to translate as accurate as possible, only the Japanese version is authentic. If there is difference in meaning of the texts between the Japanese version and the English version, text in the Japanese version are correct.

## CONTENTS

### *Glossary of Abbreviations*

1. *Progress and Process of Aircraft Accident Investigation*
  - 1.1 *Summary of the Aircraft Accident*
  - 1.2 *Outline of Aircraft Accident Investigation*
    - 1.2.1 *Investigation Organization*
    - 1.2.2 *Participation in Accident Investigation of the State concerned*
    - 1.2.3 *Period of Investigation*
    - 1.2.4 *Hearing of comments of cause-related personnel*
2. *Factual Information*
  - 2.1 *History of Flight*
  - 2.2 *Injuries to Persons*
  - 2.3 *Damage to Aircraft*
    - 2.3.1 *Extent of Damage*
    - 2.3.2 *Damage to Aircraft by part*
  - 2.4 *Damage to Other than Aircraft*
  - 2.5 *Crew Information*
    - 2.5.1 *Flight Crew*
    - 2.5.2 *Cabin Crew*
    - 2.5.3 *Other Crew*
  - 2.6 *Aircraft Information*
    - 2.6.1 *Aircraft*
    - 2.6.2 *Engines*
    - 2.6.3 *APU*
    - 2.6.4 *Escape Slides*
    - 2.6.5 *Weight and Center of Gravity*
    - 2.6.6 *Fuel and Oil*
  - 2.7 *Meteorological Information*
    - 2.7.1 *Synoptic Weather*
    - 2.7.2 *Aeronautical Meteorology*
  - 2.8 *Communication*
  - 2.9 *Airport*
  - 2.10 *DFDR and CVR*
    - 2.10.1 *DFDR*
    - 2.10.2 *CVR*
  - 2.11 *Medical Information*
  - 2.12 *Information on search, rescue and evacuation relating to survival or death of, or injury to persons*
    - 2.12.1 *Situations within the aircraft when white smoke appeared*
    - 2.12.2 *Emergency Evacuation*
    - 2.12.3 *Fire fighting and rescue service*
  - 2.13 *Tests and Research*
    - 2.13.1 *Conditions of aircraft after accident*
    - 2.13.2 *Investigation on the right-side escape slide of the upper-deck*
    - 2.13.3 *Cockpit indications*
  - 2.14 *Other necessary information*

- 2.14.1 Operational aspects of APU*
- 2.14.2 Design standards and operational aspects of the escape slide*
- 2.14.3 Cockpit indications relative to APU*
- 2.14.4 Cabin smoke detectors*

### *3. Analysis*

#### *3.1 Tests and Research for Analysis*

- 3.1.1 CMC records*
- 3.1.2 DFDR records and CVR records*
- 3.1.3 Estimation of the time when APU started*
- 3.1.4 Disassemble investigation of APU*
- 3.1.5 Investigation on damaged gears in the load gearbox*
- 3.1.6 Hardness test of gears*
- 3.1.7 System related to APU*
- 3.1.8 Sliding test on escape slide performance and precipitation*
- 3.1.9 Investigation for the injured passengers*

#### *3.2 Analysis*

- 3.2.1 Flight crew*
- 3.2.2 Aircraft*
- 3.2.3 APU starting and white smoke*
- 3.2.4 Stopping the aircraft and an evacuation command*
- 3.2.5 Captain's judgment on emergency evacuation*
- 3.2.6 Gear fracture in APU load gear box*
- 3.2.7 Mechanism of APU oil entering cabin*
- 3.2.8 Status of oil which leaked from APU*
- 3.2.9 Situation of emergency evacuation*
- 3.2.10 Time spent for emergency evacuation*
- 3.2.11 Malfunction of the upper-deck right-side slide*
- 3.2.12 Escape slide at L3 exit*
- 3.2.13 Sustained injury*
- 3.2.14 Serious injuries and age*
- 3.2.15 Bone fracture in ankle*
- 3.2.16 Evacuation from the upper-deck*
- 3.2.17 Compression fracture of spine and its contributing factors*
- 3.2.18 Precipitation and its effect on escape slide performance*
- 3.2.19 Effect of egress carrying baggages in emergency evacuation*

#### *3.3 Summary of Analysis*

### *4. Probable cause*

### *5. References*

- 5.1 TCD (Airworthiness directive) of Civil Aviation Bureau, Ministry of Transport*
  - 5.1.1 TCD regarding APU (TCD-3858-93)*
  - 5.1.2 TCD regarding APU (TCD-3861-93)*
  - 5.1.3 TCD regarding the escape slide (TCD-3999-94)*
- 5.2 AD regarding APU issued by Transport Canada (CF-93-09)*
- 5.3 AD issued by FAA*
  - 5.3.1 AD regarding APU (T93-10-51)*

- 5.3.2 AD regarding the escape slide (T94-01-15)*
- 5.4 SB issued by Pratt & Whitney Canada Co. regarding APU*
- 5.5 SB issued by Boeing Co. regarding the escape slide*
- 5.6 Safety measures taken by Civil Aviation Bureau regarding evacuations*

*Attached Figure*

- Fig.1 Boing 747-400 Three Views*
- Fig.2 Taxiing Route of Accident Aircraft at Tokyo International Airport*
- Fig.3 Emergency Exits and Escape Slides*
- Fig.4 Air-conditioning System*
- Fig.5 APU and Oil System of APU Load Gearbox*
- Fig.6 Upper-deck Escape Slide*
- Fig.7 Estimated Route of Oil leaked from APU Oil System*

*Photograph*

- Photo.1 Fractured Turbo-fan (right-side Turbo-fan of upper air chamber of upper-deck right-side escape slide)*
- Photo.2 Fragments of fractured Turbo-fan found in the upper air chamber*
- Photo.3 APU Load Gearbox*
- Photo.4 Metal Fine Flakes found on Oil Scavenge Filter of APU Load Gearbox*
- Photo.5 Fractured Cooling Fan Idler Gear*
- Photo.6 Fractured Cooling Fan Drive Gear*
- Photo.7 No.0 Bearing Air Seal*
- Photo.8 Fractured Cooling Fan Idler Gear*
- Photo.9 ~ Photo.13*
  - SEM View of Fractured Cooling Fan Idler Gear*
- Photo.14 Fractured Cooling Fan Drive Gear*

*Glossary of Abbreviations used in this Report*

<i>A C</i>	<i>Alternating Current</i>
<i>A D</i>	<i>Airworthiness Directive</i>
<i>A P U</i>	<i>Auxiliary Power Unit</i>
<i>A S B</i>	<i>Alert Service Bulletin</i>
<i>C M C</i>	<i>Central Maintenance Computer</i>
<i>C V R</i>	<i>Cockpit Voice Recorder</i>
<i>D F D R</i>	<i>Digital Flight Data Recorder</i>
<i>E G T</i>	<i>Exhaust Gas Temperature</i>
<i>E I C A S</i>	<i>Engine Indicating and Crew Alerting System</i>
<i>E V A C</i>	<i>Evacuation</i>
<i>F A A</i>	<i>Federal Aviation Administration</i>
<i>F A R</i>	<i>Federal Aviation Regulation</i>
<i>H R C</i>	<i>Rockwell Hardness C</i>
<i>L 1 (~ 5)</i>	<i>Main Deck Leftside No.1(~5) (Exit)</i>
<i>M A C</i>	<i>Mean Aerodynamic Chord</i>
<i>M H z</i>	<i>Megahertz</i>
<i>N o.</i>	<i>Number</i>
<i>R</i>	<i>Revision</i>
<i>R 1 (~ 5)</i>	<i>Main Deck Rightside No.1(~5) (Exit)</i>
<i>S B</i>	<i>Service Bulletin</i>
<i>T C D</i>	<i>Ministry of Transport, Civil Aviation Bureau, Directive</i>
<i>T S O</i>	<i>Technical Standard Order</i>
<i>U L</i>	<i>Upper Deck Leftside</i>
<i>U R</i>	<i>Upper Deck Rightside</i>

All Nippon Airways Boeing 747-400, JA8096  
Tokyo International Airport, May 2, 1993

## *1 Progress and Process of Aircraft Accident Investigation*

### *1.1 Summary of the Aircraft Accident*

All Nippon Airways flight 630, Boeing 747-400, registered JA8096, which departed Kagoshima Airport, during taxiing after landing at Tokyo International Airport on May 2, 1993, came to stop and made an emergency evacuation about 2055 hours near of Parking Spot 56 (then), because inside of the aircraft was filled with white smoke.

In the emergency evacuation, nine passengers, out of a total of 490 persons consisting of 15 crew members and 475 passengers (including 7 infants), were seriously injured.

No fire occurred on the aircraft.

### *1.2 Outlines of Aircraft Accident Investigation*

#### *1.2.1 Investigation Organization*

For investigation of this accident, the Aircraft Accident Investigation Commission appointed the investigator-in-charge and five other investigators on May 2, 1993, and two more investigators on December 1, 1993.

#### *1.2.2 Participation in Accident Investigation of the State concerned*

A representative of the Canadian Government and her advisers participated in this investigation.

#### *1.2.3 Period of Investigation*

May 2 ~ 5, 1991	Investigation at accident site and investigation of aircraft
May 4 ~ 5, 1993 and May 11 and 12, 1993	Disassemble investigation of APU
May 14, 1993	Investigation on escape slides
May 3, 1993 ~ April 22, 1994	Readout of DFDR records
May 3, 1993 ~ June 30, 1993	Readout of CVR records
Sept. 18, 1993	Test on a escape slide

#### *1.2.4 Hearing of comments of cause-related personnel*

A hearing was made from the captain.

## *2 Factual Information*

### *2.1 History of Flight*

JA8096 departed Tokyo International Airport in the early morning on May 2, 1993 as an ANA's scheduled flight, and landed Kagoshima Airport after each stop at Fukuoka, Osaka, Tokyo, and Osaka. After landing Kagoshima, the APU was started during taxiing, and was kept operating for approximately 55 minutes

until engines were started for departure.

The aircraft took off Kagoshima Airport 1931 hours as scheduled ANA flight 630 with a crew of 15 and 475 passengers (including 7 infants), a total of 490 persons on board, and landed 2050 hours on Runway 33 of Tokyo International Airport.

After landing the aircraft taxied towards Parking Spot 56 through Taxiways C8, C8B, and then Taxiway T, during which time the flight crew carried out the after-landing checks and started the APU approximately 2051 hours while passing Taxiway C8B. After passing Taxiway T the aircraft started a right turn of 90 degrees towards Parking Spot 56, and approximately 2053 hours when the aircraft was completing the right turn, the cockpit and the cabin became rapidly filled with substance like white smoke.

According to the captain, since the amount of the white smoke was increasing in the cockpit rapidly and he became cognizant by report of a cabin attendant that there were much smoke appearing also in the cabin and since the originating source was unknown and character of the smoke could not be specified, he, taking into consideration the possibility of the smoke being harmful to the human body and of fire occurring, determined to bring immediately the aircraft to a stop for emergency evacuation.

The aircraft came to stop approximately 2054 hours approximately 10 meters NE of the standing position of Parking Spot 56. A ground handling personnel who was standing by witnessed that white smoke was seen coming out of the APU exhaust when the aircraft was approaching the parking spot.

Immediately after the aircraft came to a stop, the captain commanded, through the EVAC Signal as well as the passenger addressing system, the crew and passengers to execute an emergency evacuation. About 2055 hours the flight crew also notified the Ground Control that an emergency evacuation was being carried out, with the request of fire-fighting services.

The emergency evacuation was conducted in the rain at the pavement approximately 10 meters NE of the standing position of Parking Spot 56 from all exits except for L3 using escape slides, and the evacuation was completed by about 2057 hours of all persons on board including the crew.

During the emergency evacuation, nine passengers were seriously injured.

They were transported by ambulances to hospitals in Tokyo, along with most part of less injured passengers.

Fire vehicles of the Tokyo Airport Fire Station arrived at the site about 2058 hours. Inspection by firecrew of the aircraft indicated that there had been no fire either in the cabin or in the cockpit.

The location the accident occurred was approximately 10 meters NE of the standing position of Parking Spot 56 on Tokyo International Airport, and the time the accident occurred was about 2055 hours.

Note: Parking Spot 56 was decommissioned on Sept. 27, 1993 when the new terminal building went into service, and does not exist now.



*2.2 Injuries to Persons*

Nine passengers were seriously injured, and four cabin attendants and 108 passengers sustained minor injuries.

*2.3 Damage to Aircraft*

*2.3.1 Extent of Damage*

The aircraft was slightly damaged.

*2.3.2 Damage to Aircraft by part*

APU was broken.

*2.4 Damage to Other than Aircraft*

None

*2.5 Crew Information*

*2.5.1 Flight Crew*

(1) Captain: Male, Aged 45

Airline Transport Pilot License No. [REDACTED] acquired on April 16, 1982

Type Rating

Airplane land multiple-engined	acquired on Feb.23, 1972
land single-engined	acquired on March 4, 1972
land multiple-engined	
Nikkousei YS-11	acquired on March 24, 1973
Boeing 727	acquired on Sept.19, 1974
Lockheed L-1011	acquired on Dec. 9, 1980
Boeing 737	acquired on March 16, 1988
Boeing 747-400	acquired on March 5, 1992

Class 1 Medical Certificate No. [REDACTED]

valid until June 25, 1993

Total Flight Experience	8,182 hours 25 minutes
Flight Experience on the type	331 hours 30 minutes
Flight Time in last 90 days	76 hours 55 minutes
Flight Time in last 30 days	33 hours 55 minutes
Flight Time in last 24 hours	2 hours 25 minutes
Rest period before duty hours	more than 24 hours
Captain route qualification acquired	July 6, 1992
Latest training of Emergency Procedures received	Dec. 20, 1991

(2) Copilot: Male, Aged 44

Airline Transport Pilot License No. [REDACTED] acquired on March 18, 1980

Type Rating

Airplane land single-engined	acquired on July 9, 1970
land multiple-engined	acquired on March 30, 1971
land multiple-engined	
Nikkousei YS-11	acquired on March 30, 1971
Boeing 737	acquired on June 5, 1973
Lockheed L-1011	acquired on Oct. 17, 1975
Boeing 747	acquired on Nov. 21, 1989

Boeing 747-400                      acquired on June 28, 1991  
Class 1 Medical Certificate No. 16347234

valid until Sept. 2, 1993

Total Flight Experience	10,957 hours 35 minutes
Flight Experience on the type	541 hours 45 minutes
Flight Time in last 90 days	72 hours 25 minutes
Flight Time in last 30 days	22 hours 55 minutes
Flight Time in last 24 hours	2 hours 25 minutes
Rest period before duty hour	more than 24 hours
Latest training of Emergency Procedures received	Dec. 18, 1992

*2.5.2 Cabin Crew*

- |                                      |                 |                        |
|--------------------------------------|-----------------|------------------------|
| (1) Lead Cabin Attendant             | Female, Aged 29 |                        |
| Position during emergency evacuation |                 | Door L1                |
| Employed by the Company              |                 | April 1, 1987          |
| Received Emergency Training          |                 | March 23, 1993         |
| Total Flight Experience              |                 | 4,040 hours 00 minutes |
|                                      |                 |                        |
| (2) Cabin Attendant A                | Female, Aged 27 |                        |
| Position during emergency evacuation |                 | Door L2                |
| Employed by the Company              |                 | April 11, 1988         |
| Received Emergency Training          |                 | April 22, 1993         |
| Total Flight Experience              |                 | 3,341 hours 30 minutes |
|                                      |                 |                        |
| (3) Cabin Attendant B                | Female, Aged 22 |                        |
| Position during emergency evacuation |                 | Door L3                |
| Employed by the Company              |                 | April 1, 1993          |
| Received Emergency Training          |                 | April 1, 1993          |
| Total Flight Experience              |                 | 50 hours 30 minutes    |
|                                      |                 |                        |
| (4) Cabin Attendant C                | Female, Aged 27 |                        |
| Position during emergency evacuation |                 | Door L4                |
| Employed by the Company              |                 | Feb. 10, 1986          |
| Received Emergency Training          |                 | Feb. 8, 1993           |
| Total Flight Experience              |                 | 5,026 hours 35 minutes |
|                                      |                 |                        |
| (5) Cabin Attendant D                | Female, Aged 22 |                        |
| Position during emergency evacuation |                 | Door L5                |
| Employed by the Company              |                 | April 1, 1992          |
| Received Emergency Training          |                 | April 1, 1992          |
| Total Flight Experience              |                 | 808 hours 05 minutes   |
|                                      |                 |                        |
| (6) Cabin Attendant E                | Female, Aged 24 |                        |
| Position during emergency evacuation |                 | Door R1                |
| Employed by the Company              |                 | April 25, 1989         |
| Received Emergency Training          |                 | June 19, 1992          |
| Total Flight Experience              |                 | 2,830 hours 55 minutes |
|                                      |                 |                        |
| (7) Cabin Attendant F                | Female, Aged 23 |                        |

Position during emergency evacuation	Door R2
Employed by the Company	April 13, 1992
Received Emergency Training	April 13, 1992
Total Flight Experience	744 hours 35 minutes
(8) Cabin Attendant G Female, Aged 26	
Position during emergency evacuation	Door R3
Employed by the Company	Sept. 7, 1987
Received Emergency Training	Nov. 18, 1992
Total Flight Experience	4,030 hours 05 minutes
(9) Cabin Attendant H Female, Aged 23	
Position during emergency evacuation	Door R4
Employed by the Company	May 25, 1992
Received Emergency Training	May 25, 1992
Total Flight Experience	594 hours 50 minutes
(10) Cabin Attendant I Female, Aged 24	
Position during emergency evacuation	Door R5
Employed by the Company	June 17, 1991
Received Emergency Training	June 13, 1992
Total Flight Experience	1,417 hours 40 minutes
(11) Cabin Attendant J Female, Aged 22	
Position during emergency evacuation	Door UL
Employed by the Company	July 6, 1992
Received Emergency Training	July 6, 1992
Total Flight Experience	531 hours 45 minutes
(12) Cabin Attendant K Female, Aged 25	
Position during emergency evacuation	Door UR
Employed by the Company	April 1, 1990
Received Emergency Training	March 15, 1993
Total Flight Experience	2,281 hours 05 minutes

### *2.5.3 Other crew*

A company employee observing flight operations was on the jump seat in the cockpit of the aircraft (hereinafter referred to as "observer").

## *2.6 Aircraft Information*

### *2.6.1 Aircraft*

Type :	Boeing 747-400
Serial Number :	24920
Date of Manufacture :	Dec. 13, 1990
Certificate of Airworthiness :	No. Tou 2-937
	valid while maintained in accordance with the Maintenance Manual(ANA)
Total Time :	4,917 hours 11 minutes
Time since Previous Scheduled Inspection	

(Inspection A conducted April 18, 1993) : 76 hours 02 minutes

### 2.6.2 Engines

Type :	General Electric CF6-80C2B1F			
	No.1	No.2	No.3	No.4
Serial No. :	702189	702113	702338	702417
Date of				
Manufacture :	Sept.19,1989	April 5,1989	May 16,1990	Sept.27,1990
Total Run Hours :	6,702h 18'	7,567h 14'	5,266h 55'	4,030h 55'
Run Hours since				
previous inspection:	76h 02'	76h 02'	76h 02'	76h 02'

### 2.6.3 APU

Type :	Pratt & Whitney, Canada PW901A
Serial No. :	PCE900165
Date of Manufacture :	Oct. 26, 1990
Total Run Hours :	6,757 hours

### 2.6.4 Escape Slides

On board the aircraft were equipped the following escape slides made by B.F. Goodrich Co. :

location		Escape slide		location		Escape slide	
Door	Part No.	Serial No.		Door	Part No.	Serial No.	
UL	7A1323-107	G480		UR	7A1323-107	G400	
L1	7A1467-1	G119		R1	7A1467-6	G472	
L2	7A1479-9	G317		R2	7A1479-10	G312	
L3	7A1418-17	G741		R3	7A1418-18	G756	
L4	7A1467-19	G685		R4	7A1467-4	G110	
L5	7A1469-1	G065		R5	7A1469-10	G256	

### 2.6.5 Weight and Center of Gravity

The weight of the aircraft at the time of landing is calculated as approximately 513,700 pounds and the center of gravity as 23.0 % MAC, both being within allowable limits (the specified maximum landing weight is 584,000 pounds, and the center of gravity corresponding to the weight at the time of landing is 13.0 ~ 33.0 % MAC).

### 2.6.6 Fuel and Lubrication Oil

The fuel on board was JET A-1 and the lubrication oil (hereinafter referred to as "oil") was Exxon Turbo Oil 2380 (MIL-L-23699), both meeting manufactures' specification.

## 2.7 Meteorological Information

### 2.7.1 Synoptic Weather

According to Tokyo District Weather Service Center, the synoptic weather for Tokyo area of the day of accident was as follows:

At 0300 hours May 2, 1993, the center of a high pressure was located in the offing of Sanriku, and moving east, while a low pressure was in the East China

Sea and moving ENE. The low moved during the day time to the West Japan, and a front accompanying the low moved north from the southern sea of Japan. About 2100 hours another low pressure was generated in the offing of Tokaido located on the front, and moved NE along the southern coast of Kanto for a period until 0300 hours of May 3.

In Tokyo area there was much clouds in early hours, rain started to fall from about 0700 hours in some places, and continued from day time to morning of May 3 with intermittent rain fall of less than 3 mm per hour. Wind was less than 4 meters/second until 2100 hours from about NNW to NE, and thereafter increased to some extent to 5 ~ 6 meters/second in some places. After 1500 hours the visibility became 2.2 to 2.5 km due to haze and rainfall at Ohtemachi, Chiyodaku.

### *2.7.2 Aeronautical Meteorology*

According to the Aviation Weather Service Center, Tokyo International Airport, aeronautical meteorological observations in the time zones relating to the accident were as follows:

- 2000 hours    Wind direction 340°, wind speed 12 kt  
                  visibility 2 km, weather rain, Cloud 7/8 ST 500 ft  
                  temp. 9° C, dew point 8° C, QNH 29.90 in-Hg, Remarks Haze  
                  precipitation 5mm
- 2030 hours    Wind direction 350°, wind speed 12 kt  
                  visibility 2.2 km, weather rain, Cloud 7/8 ST 400 ft  
                  temp. 9° C, dew point 8° C, QNH 29.87 in-Hg, Remarks Haze
- 2043 hours    Wind direction 340°, wind speed 14 kt  
                  visibility 2.5 km, weather rain, Cloud 7/8 ST 400 ft  
                  Remarks Haze
- 2100 hours    Wind direction 340°, wind speed 12 kt  
                  visibility 2.5 km, weather rain, Cloud 7/8 ST 400 ft  
                  temp 9° C, dew point 8° C, QNH 29.86 in-Hg  
                  Remarks Haze, precipitation 10 mm

### *2.8 Communications*

Before and after landing the aircraft had maintained communication with Tower on 118.1 MHz, and at about the time the aircraft entered Taxiway C8, the frequency was switched to 121.7 MHz for communication with Ground Control.

Communication on both frequencies was kept normal.

### *2.9 Airport*

Elevation of Tokyo International Airport is 15ft, true course of the Runway 33 the aircraft landed on is 325° 27', and the Runway 33 is 3,050m long and 60m wide paved with asphalt-concrete and grooved. (see attached Fig. 2)

The terminal building was closed on Sept. 27, 1993, when the current terminal building was put into service. The terminal building at the time of this accident was located approximately 2 km west of the current terminal building.

Taxiways the aircraft used have been kept in use, but Parking Spot 56 was deleted from AIP on Sept. 27, 1993.

### *2.10 DFDR and CVR*

The aircraft was equipped with a Fairchild Model F800 DFDR, and a Fairchild Model A100A CVR. Both equipments were installed in the aft equipment center in the aft fuselage.

#### *2.10.1 DFDR*

In DFDR were recorded in good condition all flight data of this flight from 1921:00 at which engines were started at Kagoshima Airport for departure through to 2053:59 at which all engines were shut down prior to execution of emergency evacuation.

#### *2.10.2 CVR*

In CVR were recorded voice data for a period of 19' and 25" from 2034:34 at which the aircraft was descending towards Tokyo International Airport approximately 50 nautical miles south of the airport until 2053:59 at which all engines were shut down and operation power for CVR was cut off in order to begin emergency evacuation.

The recording hours of CVR is about 30 minutes, but a part of data recorded during flight was erased, because it was re-operated for a period of approximately 10 minutes from the time the external AC power was connected to facilitate for inspection of the aircraft after the emergency evacuation, until the time the CVR circuit breaker was pulled out by a maintenance personnel.

The source of each channel of CVR was as follows and each recording condition was good:

- Channel 1 : Audio Control Panel on Observer's seat
- Channel 2 : Audio Control Panel on Co-pilot's seat
- Channel 3 : Audio Control Panel on Captain's seat
- Channel 4 : Area Microphone

### *2.11 Medical Information*

Out of a total of 490 persons on board consisting of a crew of 15 and 475 passengers, nine passengers were seriously injured. They were more than 50 years old, eight females and one male.

According to diagnosis of the hospital where they were accommodated, the nine seriously injured consists of six who sustained compression fracture of spine (four: the 12th thoracic spine, one: the 9th thoracic spine, one: the 1st lumbar spine), two who sustained other bone fracture, and one who sustained sprain and bruise, fracture of the thoracic spine, especially of the 12th thoracic spine, being remarkable.

The following are diagnosis of the injuries by the hospital and statements of the seriously injured on how they evacuated:  
(see attached Fig. 3)

(1) Female aged 68 sustained thoracic compression fracture of the 12th thoracic spine and fracture of the 4th carpal bone of the right hand; UL;

Sliding down sitting, landed like springing out from end of escape slide, and could not stand up with a pain in waist.

(2) Female aged 53 sustained thoracic compression fracture of the 12th thoracic spine; UL;

Sliding down sitting, landed like springing out from end of escape slide, could not stand up, and was carried off on other's back.

(3) Female aged 55 sustained thoracic compression fracture of the 9th thoracic spine; UL;

Sliding down sitting with pumps taken off, and holding this posture, landed from hips. She could not move for a while with a pain in waist. Assisted by other when she began to walk enduring the pain.

(4) Male aged 58 sustained open fracture of the tibia and fibula of the left lower leg; UL;

Sliding down winding the path right-to-left and being unbalanced, and landed being thrown out several meters. He could not stand up with the left foot benumbed.

(5) Female aged 72 sustained thoracic compression fracture of the 12th thoracic spine; R2;

Sliding down sitting, landed from hips like springing out from end of escape slide. She had a pain in waist.

(6) Female aged 51 sustained fracture of the left ankle; R3;

Slid down in a sitting attitude. She landed and normally stood up, but was hit by a succeeding passenger and fell down with hands touching ahead the ground at which time she had a severe pain at the left ankle.

(7) Female aged 52 sustained neck cervical sprain, and head and waist contusion ; R3;

At landing she got bruises by hitting the ground, at which time she could not walk with pains.

(8) Female aged 62 sustained thoracic compression fracture of the 12th thoracic spine; R5;

Sliding down holding a sitting posture, hips were struck at landing. She could not stand up with a pain on her back.

(9) Female aged 56 sustained thoracic compression fracture of the 1st lumbar spine ; L5;

Slid down without baggage in accordance with instruction of cabin attendants. She landed from hips. She could not stand up due to a pain in waist, but evacuated with other's help.

Besides, 108 passengers and 4 cabin attendants, 112 in total, were slightly injured. According to diagnosis of the hospital where they received treatment, their injuries were mainly abrasion, bruise, sprain among there.

*2.12 Information on search, rescue and evacuation relating to survival or death of, or injury to persons*

*2.12.1 Situations within the aircraft when white smoke appeared*

According to cabin attendants and passengers, situations within the cabin when white smoke appeared were as follows:

When the aircraft made a right turn to enter the parking spot after the aircraft landed and passing through taxiway, white smoke was seen in the cabin.

It was something like a white fog and soon found blowing out from air distribution ducts. They thought at first it was water mist coming from the air-conditioning system, but cabin attendants reported the flight crew that the cabin had been filled with smoke, because so much was coming out and filling up rapidly entire cabin, its smell was oily, and somewhat strange like a smoke signal or fire extinguisher chemicals.

Immediately after the aircraft came to stop short of the spot, EVAC signal became operated, and an emergency evacuation was ordered by the captain.

Cabin attendants could cope with the situation calmly since they were anticipating the emergency evacuation from the situation where the white smoke was filling the inside of the aircraft. Although some unrest was found among passengers, no panicky conditions arose in the cabin.

According to passengers, cabin attendants were instructing them calmly and cautioning them to lower their posture so as not to inhale smoke. They cautioned loudly not to bring baggage, and were taking away the baggage at exits, but there had been not a few passengers who evacuated with baggages such as Boston bag and handbag.

*2.12.2 Emergency Evacuation*

*2.12.2.1 Emergency training of crew*

Company regulations of ANA prescribe that flight crew and cabin attendants must receive training on emergency procedures regularly. Records of the company indicate that the crew had received the said training as described in para. 2.5.

*2.12.2.2 Actions taken by flight crew in emergency evacuation*

According to statement of the crew, CVR records and DFDR records combined, the situation at that time and actions taken by the flight crew were as follows:

The aircraft made a right turn approximately 2053 hours to enter the spot from Taxiway T, and about the time the turn was completed white smoke was seen in the cockpit. The observer on the jump seat became aware of it first, and reported to the flight crew by calling "smoke" at approximately 2053:20. By this report the captain and copilot recognized the white smoke which was filling the aft part of the cockpit



The flight crew considered at that time it was occurring only within the cockpit, inspected the instruments and others suspecting electric fire or smoke, but such evidence could not be found. Nor smell or stimulus was felt on the smoke, but it was filling rapidly the cockpit, and at about 2053:33 when they began to wondering the situation in the cabin, there was an emergency call rung on the interphone from a cabin attendant.

To the question of the copilot "Much smoke over there ?", the cabin attendant replied "Yes, much", and the flight crew recognized that the cabin was also filled with a lot of smoke.

An alternative idea occurred to the captain of proceeding to the standing position and to make normal disembarkation by the ladder, but he taking into consideration the possibility of the smoke being harm to human body and danger of fire occurring, determined to carry out an emergency evacuation, because it was smoke from unknown source and unknown cause was filling throughout the cabin. About 2053:49 the captain and the copilot communicated for executing emergency evacuation, and the captain brought the aircraft to a stop.

The aircraft stopped approximately 10 meters NE of the standing position of the spot, and about 2053:54 the captain set up the parking brake, and directed the copilot to shut down all engines and began the emergency evacuation procedures.

The captain ordered an emergency evacuation to the entire crew by operating the evacuation command switch, and then using the passenger addressing system commanded passengers and cabin attendants to make an emergency evacuation because of smoke filling the inside of the aircraft. The captain, as there was no fire recognized, did not issue any specific instructions as to use of exit doors leaving it to the discretion of cabin attendants.

The copilot shut down all engines in accordance with the direction of the captain to make emergency evacuation, and carried out as a part of emergency procedures confirmation of the out-flow valves being opened, discharge of the fire extinguisher to all engines, stopping APU and discharge of fire extinguisher to APU. Thereafter about 2054:30 he reported to the Ground Control that smoke appeared in the cabin and an emergency evacuation was being carried out, with the request of fire fighting services.

Thereafter, the flight crew rechecked completion of the emergency procedures by using the checklist, and reported to the Ground Control about 2056:00 that they were about to leave the airplane. They descended to the main-deck through the upper-deck and there they received the report of a cabin attendant still remaining at the cabin that evacuation of passengers had been completed. The captain and the copilot confirmed that there were no passengers remained in forward and the aft part of the cabin, respectively. Then they evacuated through L2 and L1 escape slide.

#### *2.12.2.3 Situation at the emergency evacuation of passengers*

According to statements of cabin attendants and passengers, the situation at

the emergency evacuation was as follows:

About the time the aircraft came to stop at the spot, white smoke was recognized in the cabin, and its amount was increasing rapidly. Soon after the aircraft came to stop, upon the captain's order make an emergency evacuation, cabin attendants opened evacuation exits and deployed escape slides in accordance with the emergency procedures. The evacuation was conducted as a whole calmly, but about 20 % of passengers evacuated carrying baggages with them.

According to the statements of cabin attendants in charge, the situation of evacuation at each exit was as follows:

(1) cabin attendant in charge of L1

She called the cockpit on the interphone to report the situation of white smoke within the cabin, but the call did not get through as if another cabin attendant seemed to have been on line. Thereafter there were EVAC signal and announcement commanding an emergency evacuation. To passengers who rose up from their seats she called out to sit and stay seated, and deployed the slide after checking the outside for safety. She instructed passengers to leave baggages in the cabin and slide down the escape slide two at a time. She instructed in general to jump and slide to male passengers, and to slide down in sitting posture to female passengers and persons with a child

(2) cabin attendant in charge of L2

She thought at first it was water vapor, but she felt it unusual because it smelled like fire extinguisher chemical, and found inside of the cabin filled with white smoke. For a moment the lighting went off, and she instructed to passengers not to worry, and reported the flight crew over the interphone that white smoke was appearing.

When she tried to open the door after EVAC signal, there was an announcement of the captain to order an emergency evacuation, she led passengers for evacuation giving priority to female passengers accompanied by infants. Since during evacuation there was found a passenger who was unable to move at the end of escape slide, she directed remaining passengers to use the opposite exit.

She cautioned them not bring baggages with them. Although passengers who were bringing large baggage abided by the caution, but those having small baggages evacuated with the baggages. The rate of passengers who evacuated having baggages was about 10 %.

(3) cabin attendant in charge of L3

When the white smoke appeared, she directed passengers to be calm, and looked outside to ascertain no irregularity such as fire.

There were EVAC signal and announcement of the captain on emergency evacuation, and operated the exit door after checking outside for safety.

However, due possibly to misoperation, the escape slide did not deploy.

Therefore she led passengers to the R3 door

(4) cabin attendant in charge of L4

When white smoke appeared from near the ceiling and the visibility was reduced to about 10 meters, the cabin lights went off for a moment and passengers became astir. Since there was no burning smell nor evidence of fire, she judged a danger was not imminent. When she instructed passengers to take a low posture, there were EVAC signal and an announcement of the captain on an emergency evacuation, then she opened the emergency exit and deployed the escape slide after confirmation of safety outside. She gave passengers caution such as to slide the escape slide sitting, to bring no baggage, to take off high-heels, and to be calm. She conducted the emergency evacuation by holding a separation so that evacuees were not hit by following evacuees.

There were few passengers who brought baggages when evacuating.

(5) cabin attendant in charge of L5

When she was going to announce the arrival of the flight, she became aware that white smoke was filling the forward part of E cabin. Since there were EVAC signal and announcement of the captain on emergency evacuation, she opened the emergency exit and deployed the escape slide after confirmation of safety outside. She called passenger's attention so as to take off high-heels and not to bring baggages with them. To the first evacuee who was male, she asked his assistance to other passengers by holding their hands.

Since warning was made so as not bring baggage, 5~6 pieces were left at the exit, but 10~20 % of passengers evacuated with baggages.

(6) cabin attendant in charge of R1

Taking notice of the smoke, when she looked to aft of the cabin, the visibility was about 6 meters. Since EVAC signal was operated, she directed passengers to be calm and to take a low posture. At that time there was announcement of the captain on emergency evacuation. Therefore, she opened the emergency exit and deployed the escape slide after confirming the safety outside. She directed the first two passengers to slide down jumping side by side, but they hesitated to do so, and slid down in a sitting start.

She directed passengers not to bring baggage, but most of them evacuated with personal belongings. For passengers having large baggages she persuaded to surrender the baggage, and received them at the exit. The number of left baggages was about 10.

(7) cabin attendant in charge of R2

She took notice of white smoke when she went out of the galley after outfitting herself for disembarkation. Since she heard the announcement of the captain on emergency evacuation after EVAC signal, she opened the emergency exit and deployed the escape slide after confirming the safety outside. She led the evacuation directing passengers to sit and slide down, and asking assistance the following persons standing up after finished sliding down.

It seemed that about 30 % of passengers evacuated with baggages, but received baggages at the emergency exit from 5~6 passengers.

(8) cabin attendant in charge of R3

She noticed of white smoke when getting out of the toilet after preparation of arrival, and judged that it was not smoke of tobacco. After she directed passengers to take it easy because it was something related with air-conditioning, EVAC signal was operated and announcement was made by the captain on emergency evacuation. Therefore she opened the emergency exit and deployed the escape slide after confirming the safety outside. She led evacuation with the instruction to release the seatbelt, not bring out baggages and to take off high-heels.

(9) cabin attendant in charge of R4

When she was going to stand up from the seat because she thought the aircraft came to the parking spot, white smoke came out from air distributing ducts of the air-conditioning system. EVAC signal was operated and announcement was made by the captain on emergency evacuation. Therefore she opened the emergency exit and deployed the escape slide after confirming the safety outside.

She instructed passengers to avoid inhaling smoke and that high-heels be taken off, no baggage be brought out with them, and directed passengers not to worry about because it was within the airport, and hold children securely.

About 20 to 30 % of passengers evacuated with baggages against her caution.

She received baggages at the emergency exit from 5~6 passengers.

(10) cabin attendant in charge of R5

Immediately after the aircraft came to a stop. she noticed that white smoke was appearing in the vicinity of E and D cabin. She judged that the amount of the smoke was of such an order to need emergency evacuation, and was anticipating instruction of the captain at the emergency exit, at which time there were EVAC signal and the announcement of the captain on emergency evacuation. She instructed passengers to stay in their seats, and after confirmed safety outside, she opened the emergency exit and deployed the escape slide. She led evacuation instructing them not bring baggage and slide down two by two.

Passengers slid down without confusion, a male standing at the end of slide held skillfully persons who were sliding down.

Most of passengers intended to evacuate with baggages, but some of them left baggage in response to the warning, and 5~6 passengers left their baggages at the exit.

(11) cabin attendant in charge of UR

About the time the aircraft came to a stop, she noticed that white smoke was coming out from air distributing ducts, and called out to passengers to lower posture and to avoid inhaling smoke by holding the headrest cover against their mouth. From the situation at that time, she was anticipating instruction of emergency evacuation at which time EVAC signal started, therefore she opened the emergency exit after confirmation of safety outside, and deployed the escape slide. But, since the escape slide was deployed somewhat aslant aft, she instructed them that the escape exit could not be used.

After a while, the slide went to a normal position, and so she let the first time two passengers slide-down. Then the slope of the escape slide became steep.

She thought it dangerous, and decided to discontinue its use, and led passengers to the exit on the opposite side (UL)

Since passengers were going to evacuate with baggages, she directed to them so as not bring them, but some escaped with baggages.

(12) cabin attendant in charge of UL

About the time the aircraft spotted in, she noticed that white smoke was coming out from air distributing ducts. The smoke spread fast than expected and the visibility became poor. She warned passengers so as to lower posture and not to breathe in smoke, at which time EVAC signal beeped. Therefore, she opened the emergency exit after confirmation of safety outside, and deployed the escape slide. Since the UR exit could not be used for some reason, most of passengers of the upper-deck escaped from the UL exit.

At the escape exit, 5~6 pieces of baggage were received. Only few passengers escaped with baggages.

#### *2.12.2.4 Statement of ground handling personnel*

According to ground handling personnel who assisted evacuees, the situation of the evacuation was as follows:

As soon as the aircraft came to a stop short of the parking spot, the escape slides were deployed, and an emergency evacuation started.

All ground handling personnel waiting the spot-in of the aircraft participated in the assistance in the evacuation at the end of escape slides. Some personnel were bumped down together with passengers as they tried to catch passengers at their front.

Some of evacuees landed as if thrown off from the end of the slide and were injured. They were led to a place away with assistance of the workers.

There was the condition that the lower ends of slides got jammed with evacuees from time to time. Some of passengers slid down holding their baggages.

#### *2.12.2.5 Escape exits and number of evacuees*

According to the investigation, the number of passengers by UR exit was 2, the number of passengers by UL exit was 56.

And according to the statements of personnel concerned, number of passengers by the other exits were as follows:

R1 and L1 : approx. 20, each.

R2, L2, R4, L4, R5, L5 : 40~50, each.

R3 : approx. 90

#### *2.12.2.6 Injured rate of passengers escaped from upper-deck or main-deck*

Out of 58 passengers on the upper-deck, the injured consist of 4 seriously injured and 18 slightly injured, with the injured rate of approximately 38 %. While out of 417 passengers on the main-deck, the injured consist of 5 seriously injured and 90 slightly injured, with the injured rate of approximately 23 %.

#### *2.12.2.7 Sliding speed on the wet slide with rain*

According to personnel concerned, the weather at the site and at the time of the accident was rain. According to meteorological observation in the time zone in which the accident occurred, precipitation was 10 mm per hour.

Most of cabin attendants stated that they felt the sliding speed on their respective escape slide was considerably faster than at the time of training, and further stated that they thought the difference could be attributable to the slides were in a wet condition with rain.

#### *2.12.3 Fire fighting and rescue service at Tokyo International Airport*

##### (1) Outline of fire fighting and rescue service at Tokyo International Airport

The fire fighting and rescue service is to be provided by Tokyo International Airport Office and the cooperation system with related organizations has been established by such plans as "Agreement on fire fighting and rescue activities at and in the vicinity of Tokyo International Airport" with Tokyo Fire Defense Board and "Agreement on fire fighting and rescue at Tokyo International Airport" with 10 companies of airlines and enterprises within the airport and setting forth "Tokyo International Airport rescue and medical care emergency program".

The fire fighting and rescue service of Tokyo International Airport office, CAB, is provided in work shifts on a 24-hours a day basis. The system such as equipments and personnel meets requirements prescribed in ICAO Annex 14 "Aerodrome".

At the time of the accident, 9 fire fighting personnel were on duty.

Note : "Related organizations" involve local public body (Otaku of Tokyo), Fire Fighting Organization (Tokyo Fire Defense Board), Police (Tokyo International Airport Police Station, Metropolitan Police Board), medical organization (Japan Red Cross, 3 medical associations in Otaku), airline companies, and airport-related enterprises.

##### (2) Request and dispatch of fire fighting services

At 2056 hours Fire Fighting Section of Tokyo International Airport Office received from Tower that fire occurred in the aircraft at Parking Spot 56 and immediately issued Class 3 Order (the alert order), and dispatched to the site two super-large chemical fire fighting vehicles, one high-speed chemical fire fighting vehicle, and one water tank truck.

The office also made one medical equipment carrier truck standing by the fire station.

In addition, at 2058 hours Tokyo Fire Defense Board, in response to the request of the commanding room of the Airport Fire Fighting Section, dispatched 47 fire fighting vehicles, out of which 3 arrived at the site, but others turned back on the way because the order was cancelled.

#### *2.13 Test and Research*

##### *2.13.1 Conditions of aircraft after accident*

A post-accident investigation of the aircraft revealed abnormal oil loss from the APU.

As to escape slides, all except L3, that is eleven escape slides in total, had been deployed.

The upper air chamber of the right-side escape slide of the upper-deck was inadequately inflated.

#### *2.13.1.1 APU access door*

The APU access door was heavily wetted with oil inside and outside.

#### *2.13.1.2 APU*

A visual external investigation was made on APU, since it was stated by eyewitnesses that white smoke was going out from the APU exhaust.

Results of the investigation are as follows:

(see attached Fig.4 and Fig.5)

(1) The inside of APU bleed air duct was inspected after removing APU isolation valve installed to the duct. The duct is the passage of compressed bleed air from the APU to the air-condition pack. The inspection indicated that the inner diameter was wet with oil and that a little oil remained on the bottom in the form of streams. There was no evidence that oil burned.

(2) The inside of load compressor discharge duct was inspected after removing diverter valve installed to the duct which divert a part of bleed air to the ambient. The inspection indicated that oil was found on the inside and 0.17ℓ of oil remained within the duct on upstream side of the valve, and 0.05ℓ within duct on downstream side(exhaustion side). There was no evidence that oil burned.

(3) It was found that the rubber tube of the breather line (which would exhaust vent air and breather air of air seal of No.0 bearing compartment as well as breather air and others of air seal of other bearing compartments) was broken and oil was leaking.

(4) The oil level sight gauges installed in the oil tank were inspected. Oil level was not visible on either upper or lower sight gauge.

#### *2.13.1.3 Engines*

Visual external inspections revealed no anomaly of engines.

#### *2.13.1.4 Positions of levers and switches of interests in cockpit and display of indicators*

Major levers positions, switches positions and display of indicators were as follows:

##### (1) Engines

- |                         |                                       |
|-------------------------|---------------------------------------|
| * thrust levers         | all engines: idle                     |
| * fuel control switches | all engines: cut-off                  |
| * Fire handles          | all engines: pulled-out, rotated ccw. |

##### (2) APU

- |                      |    |
|----------------------|----|
| * APU control switch | on |
|----------------------|----|

\* Fire handle pulled-out, rotated ccw.

(3) Pneumatic system

\* Engine bleed air switches all engines: on  
\* APU bleed air switch on  
\* Isolation valve switches left, right: open

(4) Cabin pressurization system

\* Outflow valve manual switches left, right: on  
\* Outflow valve position indicators left, right: fully open  
\* Cabin altitude auto-selector normal

(5) Air-conditioning system

\* Pack control selectors pack 1, 2 & 3: normal  
\* High flow switch off  
\* Cabin temperature selector 12 O'clock position in auto mode  
\* Cockpit temperature selector 12 O'clock position in auto mode  
\* Trim air switch on  
\* Recirculation fan switches upper, lower: on  
\* Humidifier switch off  
\* Equipment cooling selector normal  
\* Aft cargo heat switch on

*2.13.1.5 L3 emergency exit*

The L3 exit door had been opened, but the escape slide had not been deployed. The mode selector handle of the door was found in the "manual" position.

*2.13.2 Investigation on the right-side escape slide of the upper-deck*

The escape slide is expanded by high-pressure gas sent from gas cylinders and the open air. The slide consists of two air chambers, the upper and the lower chamber. The slide is usable even in case one chamber is not inflated, but in that case the time required for evacuation becomes longer because the sliding speed should be slower.

In each chamber, a turbo-fan is installed on left and right side, respectively.

The turbo-fan consists of a turbine, a fan (cast aluminum alloy) driven by the turbine and installed inside of the turbine, and a stator (cast aluminum alloy) aft of the turbine. The stator is integral with the duct of the turbo-fan, and holds the turbine and the fan.

The high-pressure gas is brought into the air chamber after rotating the turbine, and the fan is rotated by the rotation of the turbine, and the air chamber is inflated by the open air thus sucked in. The turbine and the fan rotate at 3,000 rpm (nominal). (see attached Fig.6)

At the accident the use of the right-side escape slide was suspended at the discretion of cabin attendants after two passengers were escaped because of its inadequate deployment. And it was found in the post-investigation that upper air chamber of the slide had been inadequately inflated.

Detailed investigation was conducted on the slide, and results of the investigation are as follows:



- (1) The stator of the right turbo-fan of the upper air chamber was found fractured and fan and turbine separated from each other. (see Photo.1 )
- (2) The fractured fan is rotatable not being stuck.
- (3) Investigation of fractured surface of the fractured fan and the stator showed no evidence of fatigue.
- (4) 17 brakes (maximum 8 cm in length) and more than 10 pin holes were found on the upper air chamber near the place where the right turbo-fan which was fractured is connected.
- (5) Inside of the upper air chamber were found fragments of fan, fragments of stator, and fragments of P seal (P-shaped seal of silicon rubber) attached to the bottom of the facial panel on the side of the cabin side of the escape slide. (see Photo.2 )  
Investigation of the facial panel indicated loss of the P seal.
- (6) Powdered P seal was found attached on the left-side turbo-fan of the upper air chamber.
- (7) There were no irregularities on both the left and right turbo-fan of the lower air chamber.

### *2.13.3 Cockpit indications*

#### *2.13.3.1 Cockpit indications relative to APU*

According to the flight crew, there had been no indications of anomaly in the APU. The lower EICAS display, the crew stated, was in a "blank" mode of operation in accordance with the company's operations manual. Consequently, the APU conditions which the crew could monitor were the "APU RUNNING" memo message in the upper EICAS display and the "APU generator power available" light indicating respectively that the APU was running at a proper speed range and that the electrical power was being generated at the rated voltage and frequency. Details of the APU operation such as the oil quantity were not monitored at the time.

#### *2.13.3.2 Cabin smoke detectors*

According to the flight crew, there was no indication detecting smoke on the cabin smoke detectors at that time.

### *2.14 Other necessary information*

#### *2.14.1 Operational aspects of APU*

##### *2.14.1.1 Operation of APU*

The APU can be started only on the ground. The APU, when kept operating, can supply pneumatic air up to 15,000 ft, but the electrical power is not available in flight. When the pneumatic air and electrical power are being supplied by the APU on the ground, and if the APU becomes overloaded, the priority is given to the electrical power, pneumatic air supply being automatically reduced.

#### *2.14.1.2 History, Maintenance Procedures and other information of APU*

The APU was installed on the aircraft after its manufacture, and had not been removed from the aircraft for maintenance or other reasons. Maintenance of APU is made on an on-condition basis, with inspections for oil system set forth on the following items:

- \* The main filter downstream of the oil pressure pump: every 2000 hours
- \* Magnetic chip detectors on the oil scavenge lines of the load gearbox and the accessory gearbox: every 1200 hours

Inspection was carried out on Jan. 19, 1993 on the main filter and on April 17, 1993 on magnetic chip detectors of the load gearbox and the accessory gearbox, at which times no anomaly was logged.

As to oil quantity, the company's maintenance program specifies the EICAS oil quantity and refill message be checked after each flight and the oil be replenished as necessary. The last replenishment was made on April 16, 1993.

#### *2.14.1.3 Automatic shut down of APU*

According to the Aircraft Maintenance Manual, the APU is automatically shut down when any of 21 kinds of malfunction is detected. Out of these conditions, following are related to the oil, bleed air and rotation of the load gearbox drives :

- (1) oil temperature increases to more than 135° C.
- (2) oil pressure falls below 55 psi.
- (3) bleed air temperature at the load compressor outlet exceeds 232° C.
- (4) bleed air temperature at the APU bleed air duct exceeds 121° C.
- (5) input drive gear speed exceeds 110.8% (100%=24,625 rpm)

#### *2.14.1.4 Design standards of APU*

(1) The APU was a product of Canada, and its design standards of the Canadian government mainly refers to that of U.S.A. The FAA's design standards are contained in Code of Federal Regulations, Title 14, Part 25 : Airworthiness Standards of Transport Category Aircraft (hereinafter referred to as FAR) and the Technical Standard Order (hereinafter referred to as TSO) C77a on APU which supplements the FAR. The said APU is approved by the FAA as a "Category II - Non Essential APU" conforming to the said TSO.

(2) FAR 25.1309 describes equipment, systems and installations in which principal design standards are expressed as follows:

Para.(b) The airplane systems and associated components, considered separately and in relation to other systems, must be designed so that -

- (1)The occurrence of any failure condition which would prevent the continued safe flight and landing of the airplane is extremely improbable.
- (2) The occurrence of any other failure conditions which would reduce the

capability of the airplane or the ability of the crew to cope with adverse operating conditions is improbable.

Para.(d) Compliance with the requirements of para.(b) above must be shown by analysis, and where necessary, by appropriate ground, flight, or simulator tests. The analysis must consider -

- (1) Possible modes of failure, including malfunctions and damage from external sources.
- (2) The probability of multiple failures and undetected failures.
- (3) The resulting effects on the airplane and occupants, considering the stage of flight and operating conditions.
- (4) The crew warning cues, corrective actions required, and capability of detecting faults.

(3) TSO c77a Appendix 1.6.2 describes on the safety analysis as follows:

A failure analysis must be made to show that no single failure or malfunction or probable combination of failures in any critical system of the APU will result in an unsafe condition.

#### *2.14.2 Design standards and operational aspects of the escape slide*

##### *2.14.2.1 Design standards of the escape slide*

The escape slides on board the aircraft were products of USA.

The design standards applicable to the slides are FAR and TSO C69, C69a and C69b. As to the upper-deck slides, C69 and C69a(Appendix 2 only) had been complied with.

Principal design standards excerpted from the FAR and TSOs are as follows:

(1) FAR 25.803(c)

Except as provided in para. (d) of this section, for airplanes having a seating capacity of more than 44 passengers, it must be shown by actual demonstration that the maximum seating capacity including the number of crewmembers can be evacuated from the airplane to the ground within 90 seconds.

(2) FAR 25.803(d)

A combination of analysis and tests may be used to show that the airplane is capable of being evacuated within 90 seconds under the conditions specified in para.(d) of this section if the Administrator finds that the combination of analysis and tests will provide data with respect to the emergency evacuation capability of the airplane equivalent to that which would be obtained by actual demonstration specified in para. (c) .

(3) FAR 25.809(f)(1)(ii)

The escape slide must be automatically erected within 10 seconds after deployment is begun.

(4) TSO-C69 4.23.1

The device surface, including its coating, must be suitable and safe for use in any weather condition, including a rainfall of 1 inch (2.5 cm) per hour.

#### *2.14.2.2 Time require to evacuate*

According to data of Boeing Co. it has been demonstrated that a maximum capacity of persons on board including the crew members can be evacuated from the type of aircraft within 90 seconds by using escape slides only on a single side of the fuselage.

#### *2.14.2.3 Frictional coefficient of surface materials of the escape slide*

The Boeing specification prescribes that the surface material of the escape slide must exhibit an appropriate coefficient of friction under the dry as well as wet conditions. According to B.F. Goodrich Co., the manufacturer of the escape slides, conformity of the materials to the specifications has been verified by measuring the coefficients under dry and wet conditions at the time of selection of the material in its development stage.

#### *2.14.3 Cockpit indications relative to APU*

APU-related displays and indications provided in the cockpit are described in subparagraph (1) through (4) below.

##### (1) Upper EICAS display

When the APU is operating at a specified speed ( $N_1$  at or higher than 95 %), a memo message "APU RUNNING" is displayed.

If anomaly such as fire takes place in the APU, one or more of four alert messages (like "APU FIRE") are displayed telling the nature of the malfunction.

##### (2) Lower EICAS display

When the lower EICAS display is selected in the "Status Page" mode , EGT,  $N_1$ ,  $N_2$  and Oil Quantity of the APU can be displayed.

Note: If the oil quantity falls below certain levels, the indicated oil quantity is followed by letters RF(refill) or LO(low).

##### (3) APU generator power available light

When the APU is running and output of either or both of two generators are at the nominal range, and when the generator is not connected to the aircraft AC bus, the respective "APU generator power available" light flashes on the overhead panel.

##### (4) Master warning in case of APU fire

If an APU fire breaks out, an alert message is displayed in the upper EICAS display and a master warning alert is initiated.

#### *2.14.4 Cabin smoke detectors*

The aircraft was equipped with smoke detectors at each lavatory and at the crew rest area above the L5 door. If smoke is detected by either of those, an alert message is provided to the upper EICAS display.

## *3 Analysis*

### *3.1 Tests and Research for Analysis*

### *3.1.1 CMC records*

The CMC is capable of recording in its nonvolatile memory such APU parameters as "Compartment fire", "Auto shut-down", and "Computer fault" among other records. Inspection of recorded messages indicated no evidence of malfunctions in the APU.

And inspection of the records also indicated no evidence of malfunctions in the engines, the bleed air system, air-conditioning system, or cabin pressurization system.

### *3.1.2 DFDR records and CVR records*

#### *3.1.2.1 DFDR records*

There were 106 analog flight data and 168 discrete signals recorded in the DFDR. Major findings of the records were as follows:

- (1) The UTC record contained in the DFDR was compared with other records of more accurate time base. There was a bias of three seconds which has been compensated in this report.
- (2) The DFDR readout contained no records anomaly in each system, such as smoke or fire, or operation of the aircraft.
- (3) According to DFDR records, the aircraft landed at about 2049:40, exited the runway at about 2050:30 to Taxiway C8. After passing through Taxiway C8B, the aircraft taxied along Taxiway T after about 2051:40.  
At about 2053:05 the aircraft commenced right turn to the Parking Spot 56, and completed the turn at around 2053:35, proceeded to the parking spot.  
The engines were operating at idle speed throughout of the taxiing after the thrust reversers were used for deceleration until all engines were shut down at about 2053:59.
- (4) DFDR records of any relation to APU is limited to "APU Fire", and was recorded no data indicative of occurrence of fire on the APU.

#### *3.1.2.2 CVR records*

In CVR were recorded voice and sound data for a period of 19 minutes and 25 seconds until 2053:59 at which all engines were shut down and AC power was cut off.

Major transcripts are as follows:

- (1) There were no records of irregularities indicating either system malfunctions or unusual operational condition until about 2053:20 at which time recorded was the observer's "smoke" call reporting to the flight crew of the white smoke substance entering the cockpit.
- (2) After about 2052:50, there recorded were normal communication between the flight crewmembers about identifying the marshaller, turning taxi lights off, starting a right turn in preparation for entering the gate from Taxiway T.

- (3) After about 2053:20 when a "smoke" call was recorded and until about 2053:30, conversations of the flight crew were recorded in regard to that they recognized the smoke, their attempt to identify the source, nature and extent of the smoke, and that fixes are to be carried out after stopping the aircraft.
- (4) At about 2053:33, an emergency call chime of the interphone was recorded. The record was followed by about 10 seconds conversations which includes that communication between the copilot and a cabin attendant was established, a voice of the copilot at about 2053:39 "Much smoke over there ?" inquiring the cabin attendant of the cabin condition, the attendant's answering voice "Yes, much." , and flight crew's recognition on the extent of the smoke in the cabin.
- (5) From about 2053:48, there started the captain's voice "Let's stop and evac.", the copilot's "Yeah, execute evac.", and the captain's "Okay, cut No. 1, 2, 3, 4, cut off ---" indicating that the captain decided to execute an evacuation, the copilot concurred, and they started the emergency procedures such as stopping the aircraft and shutting down all engines.
- (6) At about 2053:59 shortly after the emergency evacuation procedure was initiated, CVR recording stopped for the flight. Possibly because of this, the passenger address by the captain ordering an evacuation had not been recorded in the CVR.

### *3.1.3 Estimation of the time when the APU was started*

It is estimated that the APU was started at approximately 2051:10 judging from the statement of the flight crew that the APU was started while taxiing on Taxiway C8B and its collation with recorded data in DFDR.

It is also estimated that its operation stabilized at approximately 2051:40, since it is known from experiences that it takes about 30 seconds before the APU shaft speed increases and stabilizes.

### *3.1.4 Disassemble investigation of APU*

The following are results of the post-disassembly investigation of the APU.

#### *3.1.4.1 Load gearbox*

(1) The input drive gear, the cooling fan idler gear, and the cooling fan drive gear were found fractured. Metal chips and flakes were found on the oil scavenge magnetic chip detector located at the bottom of the gearbox case. The oil scavenge filter at the bottom was found clogged by a lot of metallic fine flakes and whiskers accumulated on it. A small amount of metallic flakes gathered in the gearbox, and there were scratches found on the inner wall.

(see Photo.3 through Photo.6)

(2) All the gear teeth (26 each) of the input drive gear were fractured at the middle part by the width of the mating gear (cooling fan idler gear).

(3) An outer part of the cooling fan idler gear (47 teeth) web was fractured

circumferentially for the length of 5 cm, or equivalent of 8 teeth. Seven of the missing 8 gear teeth were found in the metal flakes on the scavenge filter or those within the gearbox.

All of the remaining (39 each) gear teeth were smeared.

(4) Three bolts attaching the retainer of the roller bearing at the forward side of the cooling fan idler gear shaft were found loosened, but there were no irregularities on the bearing or the tab washers securing the bolts.

(5) All the teeth (24 each) of the cooling fan drive gear, which meshes with the cooling fan idler gear, were found fractured at their root. Twenty flakes corresponding to 20 out of the 24 teeth were found in the flakes either on the scavenge filter or in the gearbox case.

(6) Two out of the three bolts attaching the aft roller bearing retainer at the aft end of the cooling fan drive gear shaft were found loosened, but there were no irregularities on the bearing itself or the tab washers securing the bolts.

(7) The AC generator idler gear teeth, which mesh with the input drive gear, had indentation and metal pickup.

(8) The right hand AC generator drive gear teeth had indentation and metal pickup on the driven side of the teeth. There were no irregularities found on the left-side AC generator drive gear.

#### *3.1.4.2 Load compressor*

(1) The No.0 bearing air seal located between the load gear box and the load compressor was found intact but was heavily wetted with oil. (see Photo.7)

(2) The impeller and the inner wall of the diffuser were heavily wetted with oil.

(3) The inside of the APU bleed air duct adjacent to the APU load compressor was found heavily wetted with oil.

#### *3.1.4.3 Oil system other than the load gearbox*

(1) There remained 1.8 ℓ of oil in the oil tank. The tank capacity is 18 ℓ of which 16 ℓ is usable and 2 ℓ is unusable by design. The remaining oil quantity means that all usable oil was lost.

(2) A little amount of sandy metallic particles was found on the filter at the bottom of the oil tank.

(3) About a tea-spoonful of sandy metallic particles were trapped in the main oil filter downstream of the oil pressure pump.

(4) Several minute metallic flakes were found sticking to the oil pressure pump gears.

(5) There were several scratches found on the load gearbox oil scavenge pump.

(6) A small amount of metallic whiskers was found sticking to the magnetic chip detector in the accessory gearbox oil scavenge line. A very small amount of sandy metallic particles were found in the filter downstream of the chip detector.

#### *3.1.4.4 Exhaust duct*

Most of the inner diameter was wetted with oil.

#### *3.1.5 Investigation on damaged gears in the load gearbox*

The damaged gears were examined by both magnified visual and scanning electron microscope (SEM) inspections. Following summarizes the results.

##### *3.1.5.1 Cooling fan idler gear (see Photo.8 through Photo.13)*

Beach marks were found in two locations on the fracture surface of the gear web as well as of the corresponding teeth separated from the gear. The beach marks were found originated from the trough of the tooth and propagated to the direction of rotation.

Defects in machining, material or other kinds was not found by SEM inspection at and around the points of origin.

##### *3.1.5.2 Cooling fan drive gear (see Photo.14)*

Evidence of fatigue (with and without beach marks), having propagated toward the direction of rotation, were found at seven areas on the gear at the roots of fractured teeth. The same was found on the corresponding surface of the separated teeth. Other parting surfaces were either scored circumferentially or crushed/smeared.

Defects in machining, material or other kinds was not found by SEM inspection at and around the points of origin.

##### *3.1.5.3 Other gears*

The broken part of the input drive gear, the middle area of the gear teeth where the cooling fan idler gear meshes, had no trace of fatigue such as beach marks.

Both the generator idler gear and the generator drive gear had scoring marks on the teeth, but there were no sign of fatigue such as beach marks.

#### *3.1.6 Hardness test of gears*

The cooling fan idler gear and the cooling fan drive gear, both broken, were tested for hardness at the root of the teeth. Test results compared with the respective requirements of the Pratt & Whitney, Canada Co. are shown below:

(1) Idler gear : Lower than the specification by 6 in Rockwell "C" hardness (HRC) at 0.2mm beneath the surface.

(2) Drive Gear : Lower than the specification by 4 in Rockwell "C" hardness (HRC) at 0.2mm beneath the surface.



The insufficient hardness is presumed to have been caused by an improper surface hardening process.

### *3.1.7 Systems related to APU*

Functional tests were conducted on the APU controller unit which regulates APU operation, components regulating the APU bleed air supply system i.e. the air supply control and test unit, the APU isolation valve, and APU diverter valve and the central maintenance computer. No malfunctions were found on either unit.

### *3.1.8 Sliding test on escape slide performance and precipitation*

According to personnel concerned, it was raining at the site at the time of accident. And number of evacuees (both crew and passengers) stated that their slides were wet and attributed the slipperiness to the wet condition.

ANA carried out a series of tests, in the presence of representatives of the Aircraft Accident Investigation Commission staff, to see if sliding speed and posture were affected by wet/dry surface, jumping/sitting start and other various test condition.

#### *3.1.8.1 Test conditions*

The tests were conducted on a training mock-up of Boeing 747 L1 door fitted with a L4 escape slide. This provides almost the same condition as a L1 escape slide was used. The sill height used in the test was measured approximately 4.8 m, and the inclination approximately 32 degrees.

Three levels of surface moisture as listed below were selected as one of the primary test parameters.

- \* Dry
- \* Moderate rain (5mm/h) lasting for 30 seconds
- \* Heavy rain (15mm/h) lasting one minute

Combining the surface moisture and following test conditions, more than fifty test runs were carried out and their sliding speeds were measured.

#### (1) Testees

A male in twenties, a male in forties, a female in forties, and a box-shaped dummy sled weighting 46 kg.

#### (2) Material of clothing

Human test subjects wore cotton coveralls.

The dummy were wrapped by three kinds of clothing fabric, i.e. polyester, wool and cotton in sequence.

#### (3) Start of sliding

Jumping start (jump and slide) and sitting start (sit and slide)

#### (4) Sliding posture

- a: Arms pushed forward and arms crossed
- b: Torso held upright and laying on the back

### *3.1.8.2 Summary of results of test and analysis*

Analysis of test results in regard to correlation between the sliding speeds and test conditions as stated above (para.3.1.8.1) were as follows:

#### (1) Effect of moisture on the sliding surface

In sitting starts with the upper body kept upright, the sliding speed is slightly faster and deceleration effect at the end is less in the "moderate rain" condition. When the subjects lain on the back, increase in the sliding speed is not significant, but the deceleration effect at the lower end is similarly less when wet. In the "heavy rain" condition, sliding speed increases and the deceleration becomes worse for both torso positions.

In cases where the sliding surface is wet, the overall tendency is that sliding speeds is higher than the dry speeds and deceleration at the bottom is less. This tendency is more evident when the surface is heavily wetted ("heavy rain" condition).

#### (2) Effect of clothing materials

Tests conducted with various clothing materials wrapped on the dummy sled indicated that wool went faster and polyester slower on wet surface than dry.

Therefore, it is inferred that the sliding speeds of evacuees vary depending on clothing materials.

#### (3) Effect of starting conditions (jumping or sitting)

The maximum speed attained on the slide is somewhat larger when sliding was commenced after a jump than sitting starts. In both starting conditions, testees were decelerated significantly at the bottom of the dry slide but in wet conditions the deceleration was much less.

Jumping starts supposedly afford quicker evacuation in general than sitting starts, but the test results indicate an adverse effect of jumping starts in which the terminal speed becomes faster.

#### (4) Effect of sliding posture

Under both the dry and the wet condition, the speed on the slide is somewhat faster when sliding was made with the upper body raised than when lain on the back. Under the dry condition, the faster speed is compensated by more evident deceleration at the bottom of the slide and the terminal speeds in both postures become almost the same. Under the wet condition, testees in both postures were less decelerated at the bottom. (In the "lain on the back" tests, landing was made only onto a well cushioned mattress. Such recovery maneuvers as raising the upper body and landing on feet were not attempted at the bottom of the slide.)

### *3.1.8.3 Summary of test results*

The industry experiences show that sliding down on a dry evacuation slide in a proper posture enables normal landing on the ground, and evacuation slides are also certified for an evacuation under precipitation.

The sliding speed becomes faster in general under precipitation although starting condition, sliding posture, clothing materials and other factors can

make some differences. Therefore it is conceivable that normal landing under such condition might be somewhat difficult for the general passengers who naturally have no sliding experiences.

This tendency is believed to be intensified in a heavy rain.

### *3.1.9 Investigation for the injured passengers*

#### *3.1.9.1 Ratio of the injured by age group and in gender category*

Among the total of 475 passengers of the flight, 9 were seriously injured and 108 suffered minor injuries in the accident. The ratio of the injured by age group were approximately 10 % for those under forty, 20 % for forties, 40 % for those over fifty in age. The ratio in gender category were approximately 14 % for male and 39 % for female, and for those over fifty in age were approximately 25 % for male and 53 % for female.

#### *3.1.9.2 Circumstances and conditions of the seriously injured*

According to statement of 9 passengers seriously injured, they suffered the injuries at the time of landing after sliding down on escape slides.

While age distribution of the entire passengers on board were not unusual, all the 9 heavily injured were over fifty in age. Although the ratio of passengers over fifty in age in gender category were almost same, the seriously injured were one male and 8 female.

The break-down of injuries of the seriously injured were : 6 compression fracture of spine (the 12th thoracic spine x 4, the 9th thoracic spine x 1, the 1st lumber spine x 1) , 2 other bone fracture, 1 bruise and sprain.

Among those injuries, compression fracture of spine, especially the 12th thoracic spine, is remarkable.

NOTE : The human spinal consists of seven cervical, twelve thoracic and five lumber spines.

Each spine is named by combining zonal designation (cervical, thoracic and lumber) followed by a sequential number given downwards.

For example, a spine which belongs to the thoracic spine group and is the 12th in order when counted from the top, it is called the 12th thoracic spine.

#### *3.1.9.3 Investigation of spinal strength of the aged*

A investigation was made for spinal strength of the aged because that all of the heavily injured were aged passengers and among those injuries compression fracture of spine was remarkable.

##### (1) Change of spinal strength for age

A representative study report indicates that series of compression fracture load tests revealed that those spines of the aged are weaker in strength than those of the younger. According to the report, when compared to spinal strength of the twenties and thirties in age, those of 40s'/50s' and 60s'/70s' are 22% and 50% weaker respectively.

(H.Yamada, "Human body strength and aging", 1979)

In the bone tissue, osteoclasts (bone-absorbing cells) dissolves old bone mass while osteoblasts (bone-forming cells) add new bone structures, thus anabolism and catabolism are well balanced throughout life. If these processes become out of balance, metabolic osteomalacia results. In particular, such conditions as a result of aging is called as "osteoporosis". It is a state where bone mass is reduced while the basic bone structure is unchanged. It involves the compact layer made thinner and micro-beams in the spongy layer getting fewer and thinner, or simply stated, porous.

Conceptually expressed, osteoporosis is "a state in which mechanical strength is deteriorated due to reduction in both mineral (inorganic) content and organic (collagen) material per unit volume of the bone".  
( "Clinical orthopedic medicine" , Chugai Medical Publishing)

## (2) Osteoporosis among the male and the female

Female, in particular after menopause, suffer rapid reduction in bone mass in many cases. It is often called post-menopausal osteoporosis. It is an established theory that in female, after menopause, secretion of estrogen and protein-anabolic hormone is significantly reduced and thereby osteoblast activity is suppressed while protein-catabolic hormone is kept secreted normally and therefore osteoclast activity is maintained.

One of typical parameters frequently used for estimating bone strength is bone mass density. A study of the second through the fourth lumbar spine strength has been made on sample measurement data obtained from 916 normal (healthy) females. Peak bone mass density of each subjects was determined from measured data and statistical analysis was made. By defining probable victim of osteoporosis as those whose bone mass density is less than the average by twice the standard deviation (2SD), about 29 % of age forties, 52 % of the 50s, 78 % of the 60s, and 87% of over 70 years in age among the samples fell into this (osteoporosis) category.

(H.Kushida, "Bone fracture of the elderly", Orthopedics graphic series No.62, 1991)

In contrast, the male bears less tendency of bone deterioration due to aging.

### *3.2 Analysis*

*3.2.1 The flight crew members were properly qualified and had valid medical certificates.*

*3.2.2 The aircraft had a valid airworthiness certificate, and had been maintained as prescribed.*

### *3.2.3 APU starting and white smoke*

At approximately 2051:10, the APU was started when the aircraft was taxiing along Taxiway C8B after landing. Subsequently the aircraft taxied along the Taxiway T at an average speed of 20 km per hour and when it was about to complete a turn toward Parking Spot 56, an observer aboard in the cockpit noticed that white smoke was entering the cockpit and notified the captain by calling "smoke" at about 2053:20. The passenger cabin was also being filled by white smoke at around the time.

When a cabin attendant called the cockpit over the interphone at 2053:33, the copilot asked her "Much smoke over there ?" and she replied "Yes, much." It was at that time when the flight crew recognized that the entire aircraft was already filled with smoke.

It is estimated that after the APU was started it took about two minutes before the white smoke began appearing in the cabin.

#### *3.2.4 Stopping the aircraft and an evacuation command*

It was determined that the captain and the copilot, having noticed the smoke condition inside the aircraft, exchanged voices of coordination, brought the aircraft to a stop at about 2053:55, shut down all engines and accomplished emergency procedures which includes APU shutdown and discharging fire extinguishers among others.

The evacuation command was determined to be made by initiating the EVAC signal and through the passenger addressing system at around 2054 hours.

#### *3.2.5 Captain's judgment on emergency evacuation*

The captain stated in essence that he elected to evacuate the passengers from the aircraft as the way to best serve the passenger's safety after he could not rule out possible harm to human body and ignition/fire on the spot due to indeterminable source and nature of the smoke.

Later investigation by the commission revealed that the white smoke which filled the aircraft was atomized APU oil in mist form and it is estimated that as its density was not too high and that its being harm to human body and likelihood of ignition was negligible. It is determined that the captain, however, had no way of knowing the same under the circumstances at that time and that there were no appropriate ways he could take other than the evacuation.

#### *3.2.6 Gear fracture in APU load gearbox*

3.2.6.1 It is estimated that several teeth of the cooling fan idler gear and the cooling fan drive gear were fractured due to fatigue as was evidenced by traces of fatigue such as beach marks on the gears as stated in para.3.1.5.

It is estimated that missing teeth caused mismatching in gear engagement, resulting in fracture of the cooling fan idler gear and damage to the remaining train of the cooling fan drive gear.

3.2.6.2 The broken idler gear caused improper engagement to the mating input drive gear, which made the cooling fan idler gear battered by the input drive gear with resultant damages to the input drive gear.

3.2.6.3 The damaged input drive gear caused secondary damages to the meshing generator idler gear and subsequently to the generator drive gear engaged to the generator idler gear.

3.2.6.4 As stated in para. 3.1.4, it was recognized that bolts attaching the retainer for the bearings which support the cooling fan idler shaft and the cooling fan drive gear shaft.

It is reasonable to assume that these loosening was the result of high load

caused by the gear breakage but the possibility can not be ruled out that the loose condition was pre-existing due to APU vibration and case resonance.

3.2.6.5 The fatigue cracks in the idler gear and the drive gear of the cooling fan are considered to have been caused by vibration of the cooling fan shaft due to APU vibration during running and to resonating casing. Inadequate hardness of the gear teeth, presumably as a result of insufficient carbonization, is considered to have contributed to the fatigue cracking.

### *3.2.7 Mechanism of APU oil entering the cabin*

3.2.7.1 The APU load gearbox is lubricated by sprayed oil provided from various nozzles. The pressure of the oil is 80 psi and the temperature 82° C (Both nominal value).

3.2.7.2 The front end of the APU N<sub>1</sub> shaft is supported by the No.0 bearing in the load gearbox whose cavity is separated from the load compressor by the No.0 bearing air seal.

N<sub>2</sub> compressor pressure, which is higher than the load gearbox pressure, is provided as the back pressure for the No.0 bearing seal. The pressure differential of a few psi prevents the lubricating oil for the No.0 bearing from entering to the load compressor.

3.2.7.3 According to CMC records, DFDR records, investigation of the aircraft and statements of the captain and the copilot, there were no anomaly in engines and the APU was started normally and was in operation supplying only pneumatic air.

As the engine bleed air is approximately 45 psi and the APU pneumatic air is approximately 56 psi, it is determined that at that time the APU was the primary source of pneumatic air for the air-conditioning system.

3.2.7.4 As was stated in para. 3.1.4.1 (1) , several gears were found broken in the load gearbox and substantial amount of metal particles were found accumulated on the oil scavenge strainer. From these findings it is concluded that the metal particles clogged the oil scavenge strainer, that the oil could no longer be drained adequately, that the incoming oil exceeded the impaired scavenging capability, and that the internal pressure of the load gearbox became as high as exceeding the back pressure at the No.0 bearing air seal.

It is estimated that a majority part of the leaking oil that was sprayed into the load compressor and got atomized entered the APU bleed duct and subsequently a limited part which turned into a "dry mist" state went into the air-conditioning system.

It is also estimated that a part of oil sprayed into the load compressor went through the diverter valve and then to the ambient.

3.2.7.5 It is estimated that a part of oil that leaked through the air seal passed through the sealing air passage and through the breather line and was

finally purged through the exhaust duct. A cracked rubber tube on the line indicates that oil leaked from there and wetted the APU access door.

(see attached Fig.7)

### *3.2.8 Status of oil which leaked from APU*

3.2.8.1 Investigation of the aircraft showed no evidence that oil burned, although oil was found sticking to inside of APU load compressor, APU bleed air duct and others. None of the over heat protection of each system detected over-heating as follows:

(1) APU is designed to stop automatically when the over-heat switches which are installed to APU bleed air duct operates, but APU did not stop automatically.

(2) In the air-conditioning system are installed two protections for over-heat (operates at 218° C) and pack discharge over-heat (operates at 85° C) of the air cycle machine, and when they operate, the air-conditioning system would usually stop. But the air-conditioning system did not stop.

(3) The location where the temperature of air is highest in the portion from APU to air exit of the passenger cabin is the exit of the load compressor, and temperature would have been approximately 220° C for the air temperature of 9° C at that time. According to Exxon's data, the flashing point of oil is 249° C, and ignition point (natural ignition temperature) is 415° C, higher than the temperature above. There is no ignition source between APU air intake to cockpit and passenger cabin's air blow.

From the above, it is estimated that oil did not burn.

3.2.8.2 It is estimated that oil leaked into the load compressor in a sprayed form and became minute particles of oil by dispersing within the load compressor and mixing with bleed air, judging from the fact that the space between No.0 bearing seal and air seal bore is as narrow as approximately 0.02 in (0.5 mm) and load compressor impeller is making a high-speed rotation. It is estimated also that comparatively large particles collided with the inner wall and stuck to the inner wall while minute particles having comparatively large surface tension became mist being mixed with the bleed air, and sprayed into passenger cabin and cockpit from air distributing ducts.

Minute foggy oil particles are not subjected to effect of change in environments such as cooling or depression, and does not change the state even if through the long draft tube, and such oil particles are referred to as "dry mist" in the engineering, being used for lubrication of machinery.

### *3.2.8.3 Amount of oil leaked*

The capacity of oil tank is 18 ℓ, and the capability of the oil pump of the load gearbox is about 10 ℓ/minute. From the fact that the investigation showed oil of 1.8 ℓ remained in the oil tank, it is estimated that approximately 16 ℓ of oil had leaked in slightly less than 2 minutes after the load gearbox oil scavenge filter was blocked up.

### *3.2.9 Situation of emergency evacuation*

Order of the captain on the emergency evacuation was announced about 2054 hours through EVAC signal and the passenger addressing system within the aircraft.

Cabin attendants stated that they deployed escape slides without delay, because they were anticipating an order on emergency evacuation from the condition of the white smoke filling the cabin, and on the other hand ground workers stated that escape slides were deployed soon after the aircraft was brought to a stop.

From these it is estimated that the emergency evacuation procedures were implemented expeditely by cabin attendants.

### *3.2.10 Time spent for emergency evacuation*

According to the record of communications between the aircraft and Ground Control, the flight crew reported to Ground Control their evacuation about 2056:00 hours, and according to the captain, when the flight crew went to the passenger cabin after reporting to Ground Control, evacuation of passengers had been completed. It is, therefore, estimated that the time spent for completion of evacuation of passengers would have been within 2 minutes after the emergency evacuation was directed.

### *3.2.11 Malfunction of the upper-deck right-side slide*

#### *3.2.11.1 Inadequate deployment of the upper-deck right-side slide*

According to the cabin attendant in charge of upper-deck right-side exit, the slide was deployed somewhat aslant aft at first, then seemed to be normal, but evacuation was suspended at her discretion because that the slope of the the slide became steep at the time when the first two evacuees slid down.

In the post-accident investigation it was found that the upper air chamber of the slide had been inadequately inflated.

As stated in para. 2.13.2 the investigation indicated 17 brakes and more than 10 pin holes at the vicinity of the location where the slide is connected with the right-side turbo-fan of the upper chamber. It is estimated that the inadequate deployment of the slide was due to insufficient inflation of the chamber with the result that the open air was not sucked in sufficiently due to the turbo-fan fracture, and a part of the sucked in air would have leaked through the brakes and pin halls of the chamber which were made by the fractured blades of the fan and stator.

#### *3.2.11.2 Fracture of the turbo-fan*

As stated in para. 2.13.2, there was found in the upper chamber fragments of P seal attached to facial panel installed on the cabin side wall of the escape slide together with fragments of turbine, fan and stator of the right-side turbo-fan, and there were no evidence of fatigue of fractured surfaces of the fan and stator. Therefore, as the causes the turbo-fan was fractured the following are considerable:



(1) P seal came off and was sucked into the turbo-fan and collided with the fan, resulting in overload to the fan, with the result that the fan and the rotor were separated from each other, fragments of the fan bit the stator, and the stator fractured.

(2) P seal came off and was sucked into the turbo-fan and the fan was restrained, resulting in rapid reduction of rotating speed, and thereby overload to the stator holding the fan was caused, with the result that the stator was fractured, and fragments of the stator bit the fan, and the fan fractured, and fan and rotor separated from each other.

As to the cause the P seal came off, insufficient adhesion to the facial panel at the time of manufacture is considerable.

#### *3.2.12 Escape slide at L3 exit*

As stated earlier in para.2.12.2.3 (3) and 2.13.1.5, the L3 door was opened but its slide did not deploy. Examination revealed that the mode selector handle of the door was placed in the "Manual" position.

When a deployment test was later conducted with the mode selector handle in the "Auto" position, the slide deployed normally. Consequently it is concluded that the slide did not deploy because the cabin attendant inadvertently moved the handle to the "Manual" position immediately before opening the door.

#### *3.2.13 Sustained injury*

The seriously injured evacuees were mostly bone fracture while the slightly injured evacuees suffered mainly bruise, sprain and scratch while.

According to the injured, the seriously injured got injured when landing, and the slightly injured while going down the escape slide or when landing.

As there were no evident panic in mass behavior causing injuries, it is determined that the injuries occurred on the slide or at the time of landing.

As stated in para.2.14.2, evacuation slides are designed primarily to facilitate quick evacuation in emergencies like fire. It is therefore anticipated injuries in an emergency evacuation might become inevitable if certain factors adversely affect sliding conditions.

#### *3.2.14 Serious injuries and age*

As stated in para.3.1.9, there was no unusual peak in passengers' age distribution of flight, but the all nine seriously injured were over 50 years old, among whom eight were diagnosed as bone fracture and the other one sustained sprain and bruise.

The elderly are generally known to be physically weaker and less athletic than the younger, and their spine, especially in female, deteriorates with age. This tendency may have been one of factors contributing to the finding that all the seriously injured in the accident were over 50 years old.

#### *3.2.15 Bone fracture in ankle*

The seriously injured passenger who sustained bone fracture in the left ankle is supposed to have suffered the injury when she fell down as a following

passenger bumped her, either because she stayed there or a sliding interval was short.

### *3.2.16 Evacuation from the upper-deck*

As stated in para.2.12.2.6, injury (minor injuries included) rate of the evacuees from the upper-deck was approximately 38%, which is higher than that of the main-deck (23%). In addition, four out of the nine seriously injured were evacuees from the upper-deck.

The upper-deck exit doors is approximately 7.8 m high at the sill and is located above the main-deck doors. The longer sliding path from the upper-deck might make it difficult for evacuees to maintain a balanced sliding posture, and it is conceivable that this tendency may have been one of contributing factors of the injuries.

### *3.2.17 Compression fracture of spine and its contributing factors*

As stated in para.3.1.9, eight passengers out of the nine seriously injured were female over 50 years of age. Sustained injuries include compression fracture of spine to 6 people (four: the 12th thoracic spine, one: the 9th thoracic spine, one: the 1st lumbar spine), other bone fracture to 2 people and sprain/bruise to one. Among those, compression fracture of thoracic spine especially the twelfth thoracic (T12) spine, stood out.

As was discussed in para.3.1.9.3, bone deterioration due to aging progresses more evidently in the spinal column than other kinds, and the female are subject to faster aging effect than the male.

Accordingly, bone aging among the elderly passengers is considered to be one of major factors contributing to the fact that the majority of the serious injuries sustained compression fracture of spine.

### *3.2.18 Precipitation and its effect on escape slide performance*

According to personnel concerned, it was raining at the time and the site of the accident. Several of passengers and crew members also stated that their slides were wetted and slippery. Meteorological observation records of the Airport Aviation Weather Service Center indicates rainfall was at 10 mm/hr between 2000 and 2100 hours.

As stated in para.2.14.2, the aircraft manufacturer's specification requires appropriate frictional coefficients of the sliding surface material under both the dry and the wet conditions. B.F. Goodrich Company, the manufacturer of the escape slides, notified the committee that the sliding surface material has been tested for conformity to the Boeing specifications.

From the sliding test described in para.3.1.8 it looked reasonable to assume that escape slides, if wet, are serviceable for intended use, but it was also observed that the higher sliding speed and less deceleration at the lower end on a wet slide might make it difficult in some cases for evacuees to land in a normal posture.

According to the seriously injured passengers, all of them sustained injuries at the time of landing. The effect of the wetted slide might be one of

contributing factors of this situation.

### *3.2.19 Effect of egress carrying baggages in emergency evacuation*

Sliding down an evacuation slide with baggages in hand is considered in the industry to compromise/impair safe evacuation and therefore it is a general practice for airlines to warn passengers not to bring baggages with them.

In this accident, it is assumed from statements of the cabin attendants, some of passengers and ground personnel that about 20 % of evacuees were carrying baggages although cabin attendants directed not to do so. This is considered to be one of causal factors of injuries.

### *3.3 Summary of Analysis*

*3.3.1 The aircraft landed normally and was taxiing on a taxiway when the APU was started. About two minutes later, white smoke appeared in the passenger cabin and the cockpit.*

*3.3.2 The flight crew recognized the white smoke and stopped the aircraft immediately, and an emergency evacuation was commenced as commanded by the captain. It is estimated that it took about two minutes before all the passengers evacuated.*

*3.3.3 It is assumed from investigation that the white smoke at the density virtually contained no risk of causing harm to human bodies or ignition.*

*However, it is determined that the captain had no way of knowing the source or the nature of the white smoke under circumstances at that time and that there were no alternative for the captain to follow other than commencing an emergency evacuation for the sake of passengers' safety.*

*3.3.4 The probable sequence of the white smoke is determined that the cooling fan idler gear, cooling fan drive gear, and input drive gear broke in the load gearbox during APU operation, that their broken pieces were accumulated on the oil scavenge filter of the gearbox and the filter was clogged, that the clogged filter caused increased pressure within the gearbox exceeding the back pressure at the No.0 bearing air seal, that the trapped oil in the gearbox leaked to the load compressor area through the bearing seal, and that a part of the leaked oil entered the cabin through the aircraft's air-conditioning system while another part of oil went out of the aircraft from APU exhaust.*

*3.3.5 As to breakage of the cooling fan idler gear and the cooling fan drive gear, it is estimated that cooling shaft vibration and other factors caused their inadequately hardened gear teeth to crack, which in turn adversely affected meshing of the gears and thereby caused the gears to break down.*

*3.3.6 The APU oil is considered to have been either atomized or vaporized mainly in the load compressor, when considering the fact that the clearance at the No.0 bearing air seal (outer diameter of the seal to the inner diameter of the bore) is as little as 0.02 inch (0.5 mm) in diameter, that the load compressor is of a high-speed centrifugal type, and that the temperature in the load compressor is high.*

*3.3.7 It is considered that large particles in the atomized oil and some of vaporized oil sticking to the inner wall of the ducts while minute particles which are less affected by temperature does not change the state due to their physical properties, resulted in dry mist state which finally entered the cabin.*

*3.3.8 Machine industry experience shows that lubricating oil in "dry mist" state generally look like smoke in white color rather than the amber color in which the oil is known to be. The dry mist oil therefore may have been regarded as white smoke filling the cabin.*

*3.3.9 It is estimated that the upper-deck right-side slide was deployed inadequately because one of its turbo-fans broke and was inoperative, so the open air was not sucked sufficiently in to the upper air chamber, and because the upper air chamber was damaged when fragments of the broken fan penetrated it.*

*3.3.10 It is estimated that a P seal, used on the facial panel located normally between the stored slide and the cabin, separated from the panel, was sucked into the turbo-fan and caused its blades to fracture by overload.*

*3.3.11 It is determined that the seriously injured evacuees sustained injuries when they slid down the evacuation slides onto the ground.*

*Serious injuries could be attributable to that the slides were wet, that evacuation from the upper-deck was involved, that some of evacuees carried baggages. And it is considered all these conditions were hard for the elderly, especially for the elderly women.*

#### *4 Probable cause*

*It is estimated that the failure of gears in the APU load gearbox caused APU oil to jet-leak and get atomized into the air system and consequently filled inside the aircraft as dry mist. Therefore an emergency evacuation was conducted, and during evacuation several passengers were seriously injured as they slid down the escape slides onto the ground.*

#### *5 References*

*5.1 TCD(Airworthiness Directive) of Civil Aviation Bureau, Ministry of Transport*

*5.1.1 TCD regarding APU (TCD-3858-93)*

*On May 7, 1993, the Civil Aviation Bureau issued a TCD(TCD-3858-93) and, to prevent APU gearbox failure, directed the users of B747-400 to inspect the APU magnetic chip detectors of the load gearbox and accessory gearbox followed by the interval inspection and, if necessary, to change the APU.*

*5.1.2 TCD regarding APU (TCD-3861-93)*

On May 14, 1993, the Civil Aviation Bureau issued a TCD(TCD-3861-93) and, to prevent smoke contamination of passenger cabin, directed the users of the aircraft installed with the Pratt & Whitney Model PW901 APU to remove the oil strainer element from the load gearbox within 10 APU cycles, or 5 days, or at the first visit to a maintenance base capable of accomplishing the requirements of this TCD, whichever occurs first. This TCD is based on Airworthiness Directive(CF-93-09) issued by Transport Canada.

#### *5.1.3 TCD regarding the escape slide (TCD-3999-94)*

On April 19, 1994, Civil Aviation Bureau issued a TCD(TCD-3999-94) for Boeing Model 747 series with a stretched upper-deck, that the P seal shall be fixed with a metal retainer within 6 months to prevent the P seal from coming off the facial panels and being ingested into the turbo-fans of the escape systems, which could impede the inflation of the escape slide.

This TCD was based on FAA AD(94-01-15).

#### *5.2 Airworthiness Directive regarding APU issued by Transport Canada (CF-93-09)*

Transport Canada issued an emergency airworthiness directive (CF-93-09) (May 13, 1993) as follows.

There have been two incidents in which smoke entered the aircraft passenger compartment after the fracture of APU idler gear and cooling fan shaft. Debris from the fractured gears blocked a fine scavenge strainer and resulted in flooding the load gearbox, allowing oil to enter the load compressor air system.

To prevent smoke entering the aircraft components in case of idler gear and cooling fan shaft failure, remove the oil strainer element, within 10 APU cycles, or 5 days, or at the first visit to a maintenance base capable of accomplishing the requirements of this AD, whichever occurs first.

#### *5.3 Airworthiness Directive issued by FAA*

##### *5.3.1 AD regarding APU (T93-10-51)*

On May 20, 1993, FAA issued an emergency AD(T93-10-51) regarding the Pratt & Whitney Canada Model PW901A APU requiring the users to remove the oil strainer element within 10 APU operating hours or 5 days after the effective date of the AD, and to inspect the APU load gearbox and accessory gearbox magnetic chip detector at intervals not to exceed 150 APU operating hours since the last inspection.

##### *5.3.2 AD regarding the escape slide (T94-01-15)*

On January 15, 1994, FAA issued an AD(T94-01-15) for Boeing Model 747 series airplanes with a stretched upper-deck to install an aluminum seal retainer on the P seal attached to the facial panel of the escape systems of the upper-deck in accordance with Boeing Alert Service Bulletin No.747-25A3056 (July 12, 1993) within 6 months after the effective date of the AD.

#### *5.4 Service Bulletin issued by Pratt & Whitney Canada Co. regarding APU*

Pratt & Whitney Canada Co. issued the Alert Service Bulletins, No.A16159(May 7, 1993), No.A16159R1(May 12, 1994) and No.A16159R2 (October 18, 1993) regarding Model PW901A APU, for the modification which requires the oil scavenge strainer

to be removed so as to allow the debris to pass into the scavenge oil pump causing the APU shutdown.

Additionally, Pratt & Whitney Canada Co. issued Service Bulletin, No.A16161(July 12, 1993) and No.A16161R2(November 1, 1993) for the modification which requires the load gear box scavenge screen to be introduced of a scavenge screen of increased flow area, and the load gearbox scavenge pump to be replaced with an increased capacity pump.

Further more, they issued Service Bulletin, No.A16170(June 16, 1994) and No.A16170R1(August 5, 1994), regarding the modification for the replacement of the cooling fan drive spur gearshaft and idler spur gearshaft introducing an improved cooling fan housing, a new cooling fan drive shaft arrangement and so on.

#### *5.5 Service Bulletin issued by Boeing Co. regarding the escape slide*

Boeing Co. issued Alert Service Bulletin, No.747-25A3056 (July 12, 1993) and its Revision(February 3, 1994), regarding the modification to install an aluminum seal retainer on P seal attached to the facial panel of the escape systems, as to prevent the P seal from coming off the facial panels and being ingested into the turbo-fans of the escape systems on the upper deck.

#### *5.6 Safety measures taken by Civil Aviation Bureau regarding evacuations*

On May 17, 1993, Civil Aviation Bureau started to study by forming a group regarding the evacuation from the large airplanes, which members are composed of CAB staffs and staffs who are responsible for the cabin safety in the three major airliner companies, and which purpose was to review the evacuation safety information for passengers.

Receiving the report from the study group, Civil Aviation Bureau instructed a review of the passenger information about the evacuation procedures to the seven schedule airliner companies and two non-schedule international airliner companies on July 28, 1993.

In consequence, the airliner companies improved the cabin attendants demonstration, the evacuation instruction video and the safety instructions guide for passengers to be known more about sliding technique, assistance and leaving away from the ends of slides.

Fig.1 Boeing 747-400 THREE VIEWS

unit : m.

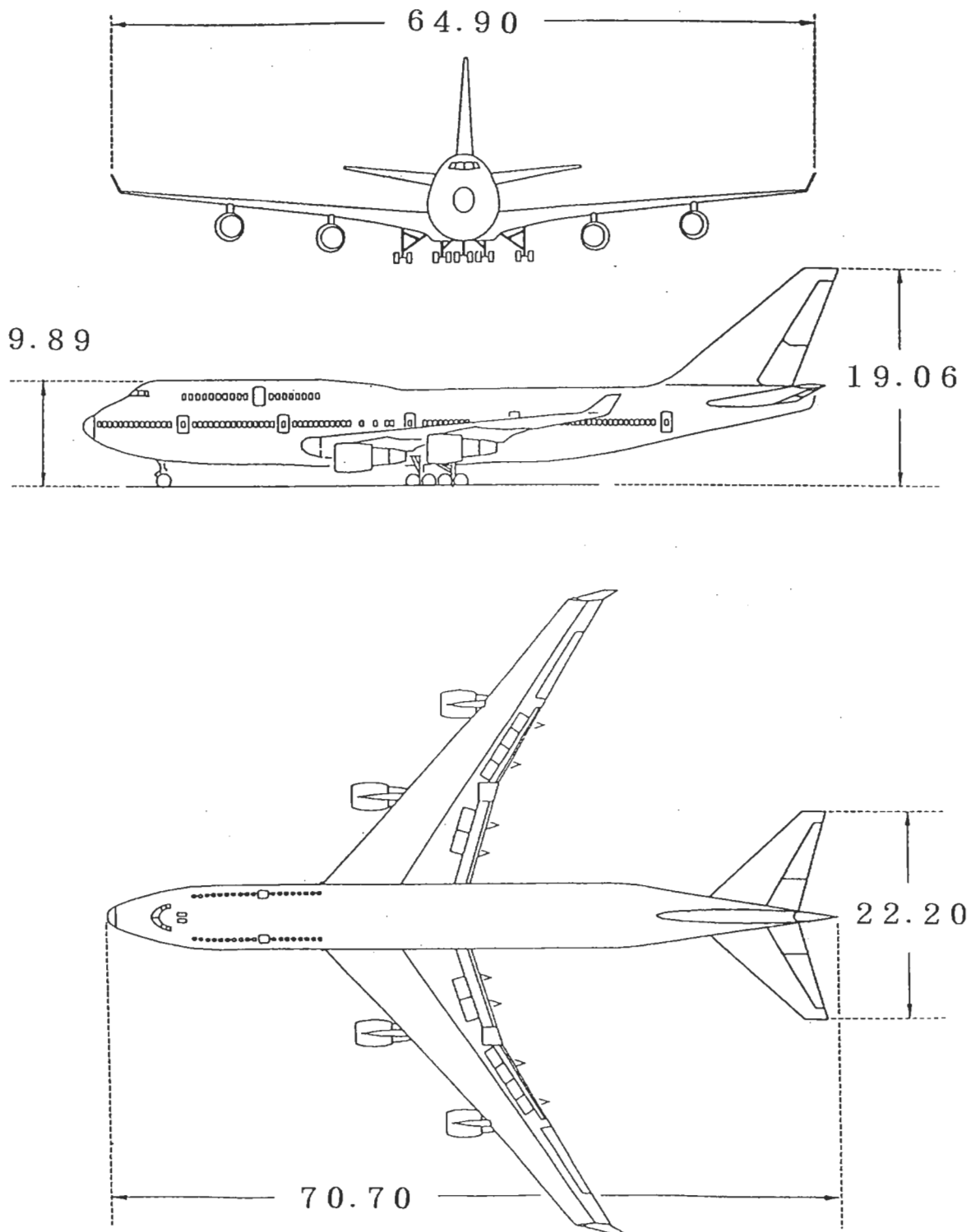
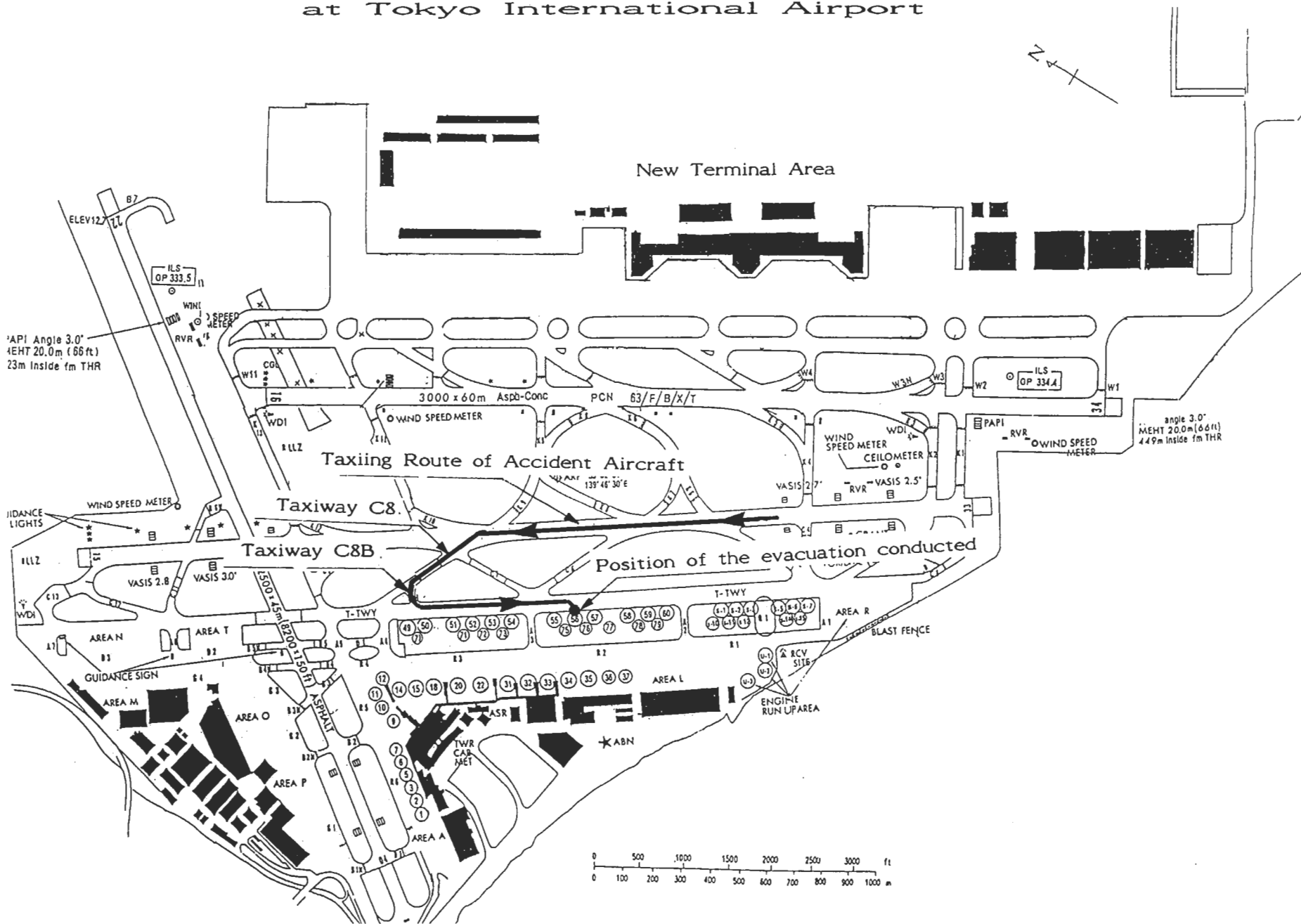

Fig.2 Taxiing Route of Accident Aircraft  
at Tokyo International Airport



- 42 -



Fig.3 Emergency Exits and Escape Slides

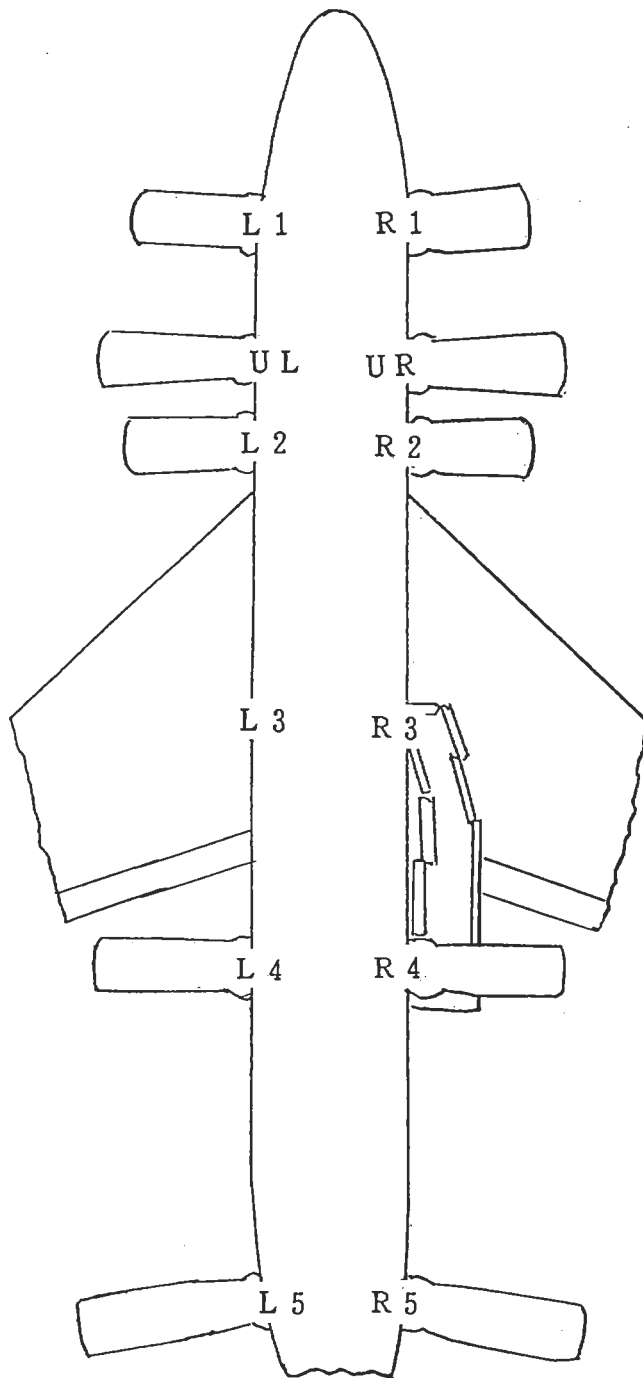

Note1: L3 exit was not used

Note2: sill height of slide

exit	UL, UR	L1, R1	L2, R2	(L3), R3	L4, R4	L5, R5
sill height(m)	7.77	4.74	4.82	4.92	5.00	5.11

Fig.4 Air-conditioning System

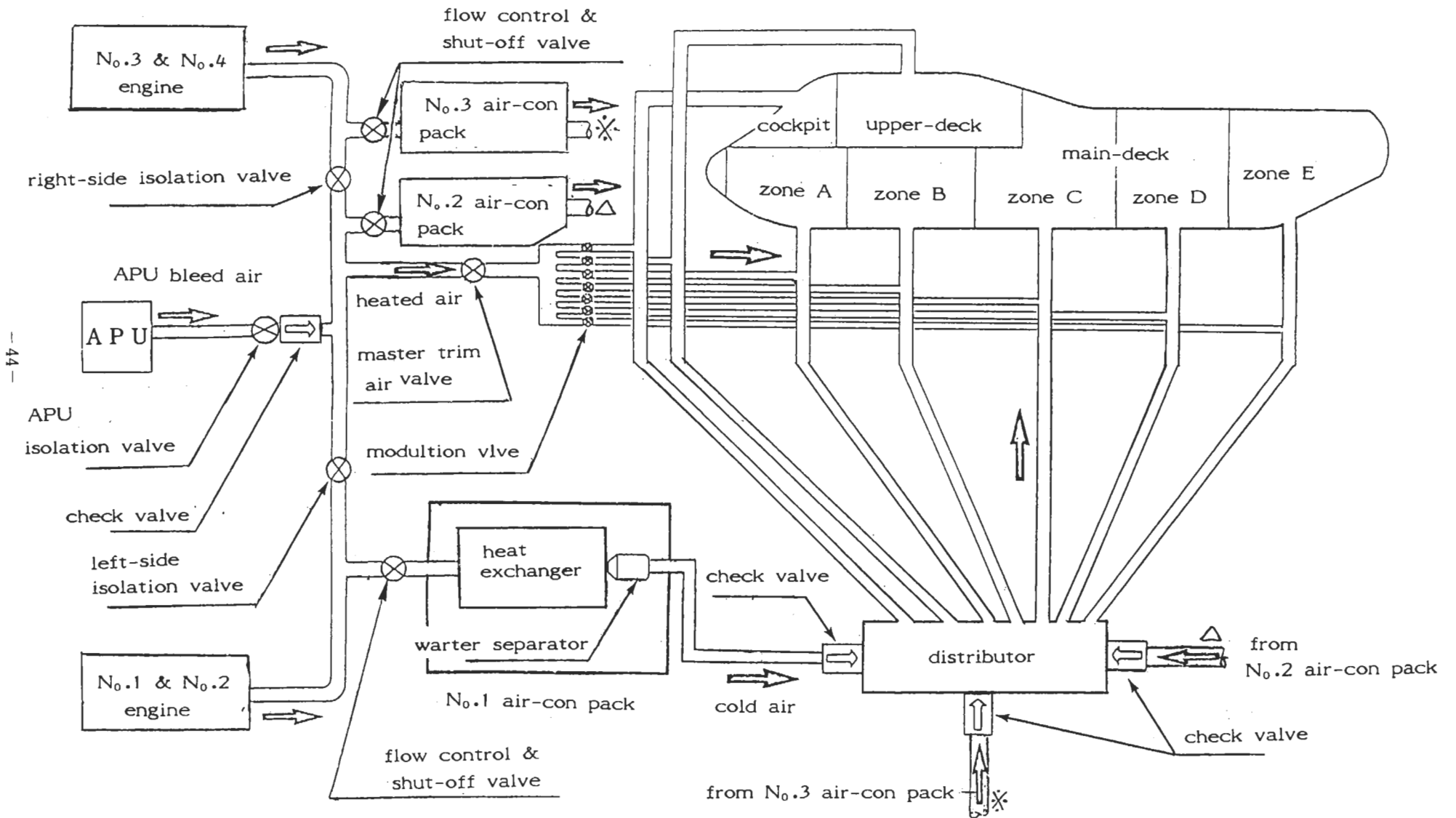

Fig.5 APU and Oil System of APU Load Gearbox

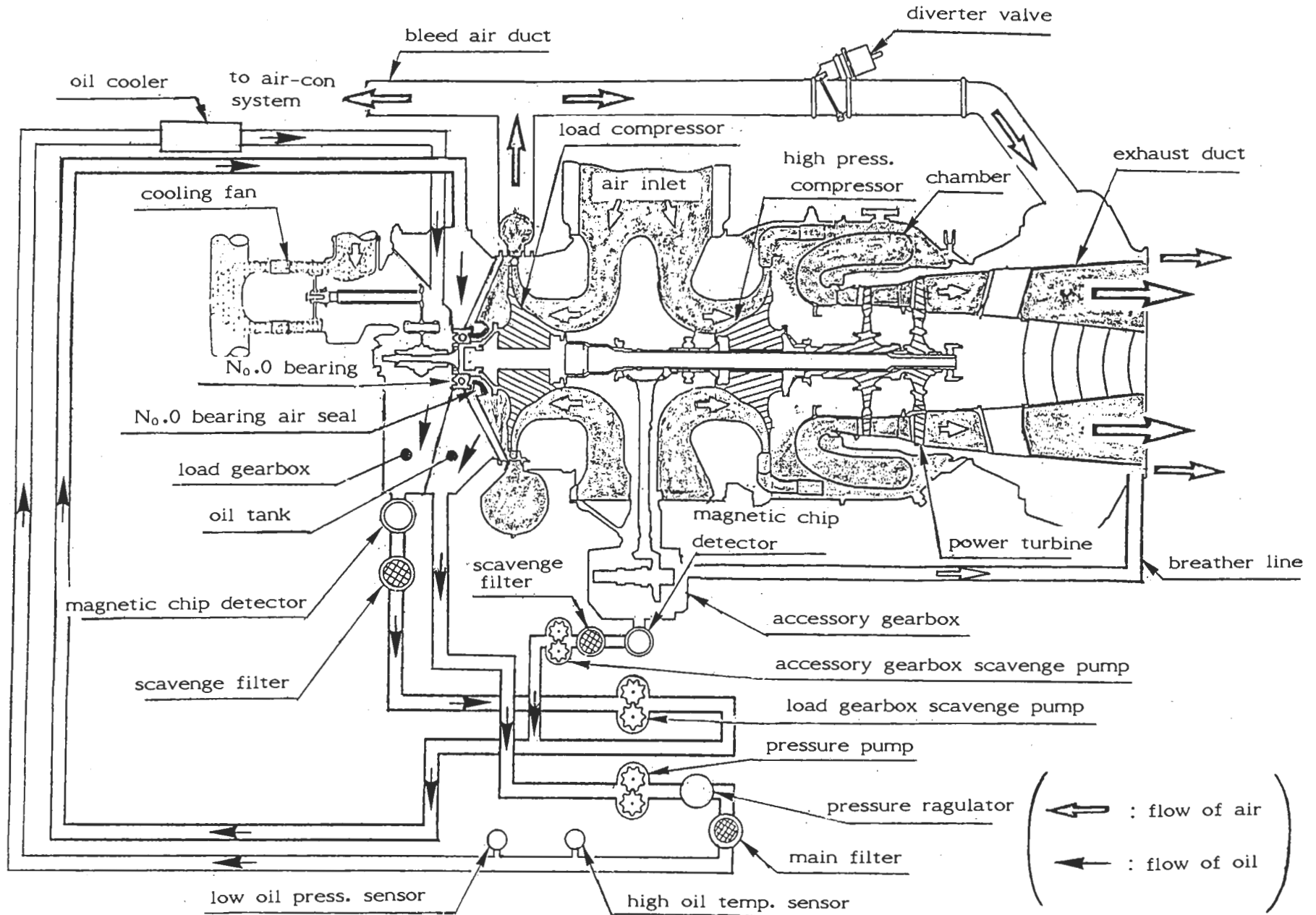

Fig.6 Upper-deck Escape Slide

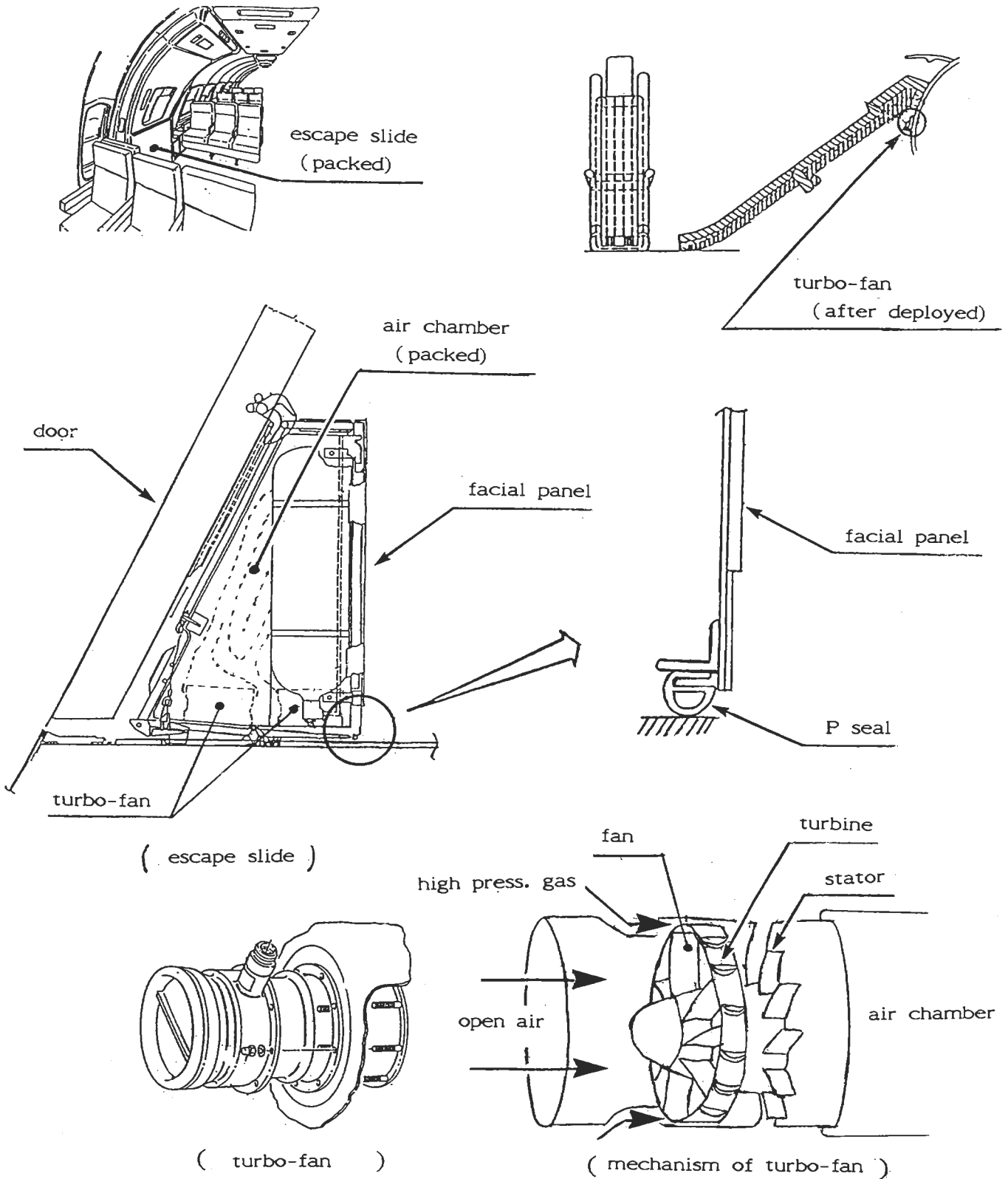

Fig.7 Estimated Route of Oil leaked from APU Oil System

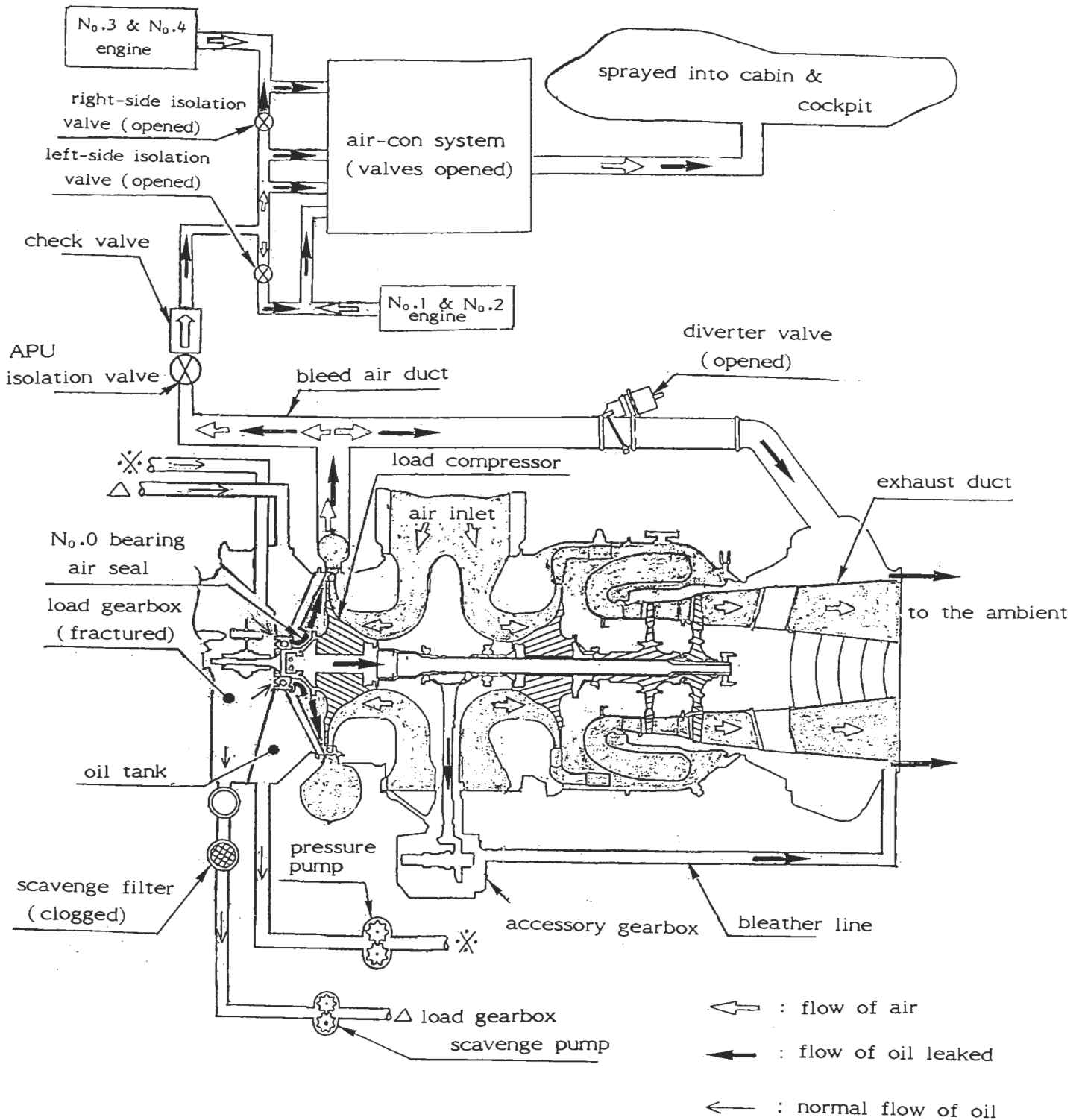

Photo. 1 Fractured Turbo-fan (right-side Turbo-fan of upper air chamber of upper-deck right-side escape slide)

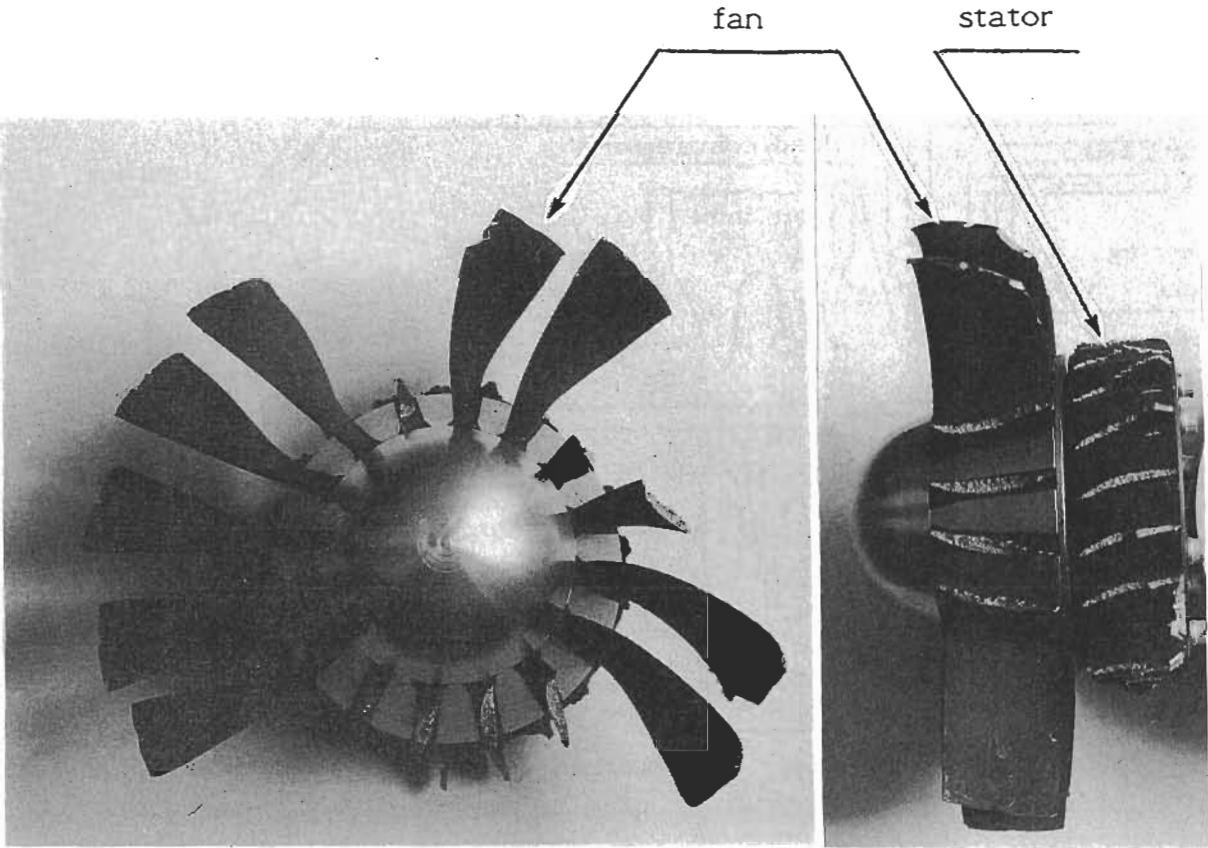
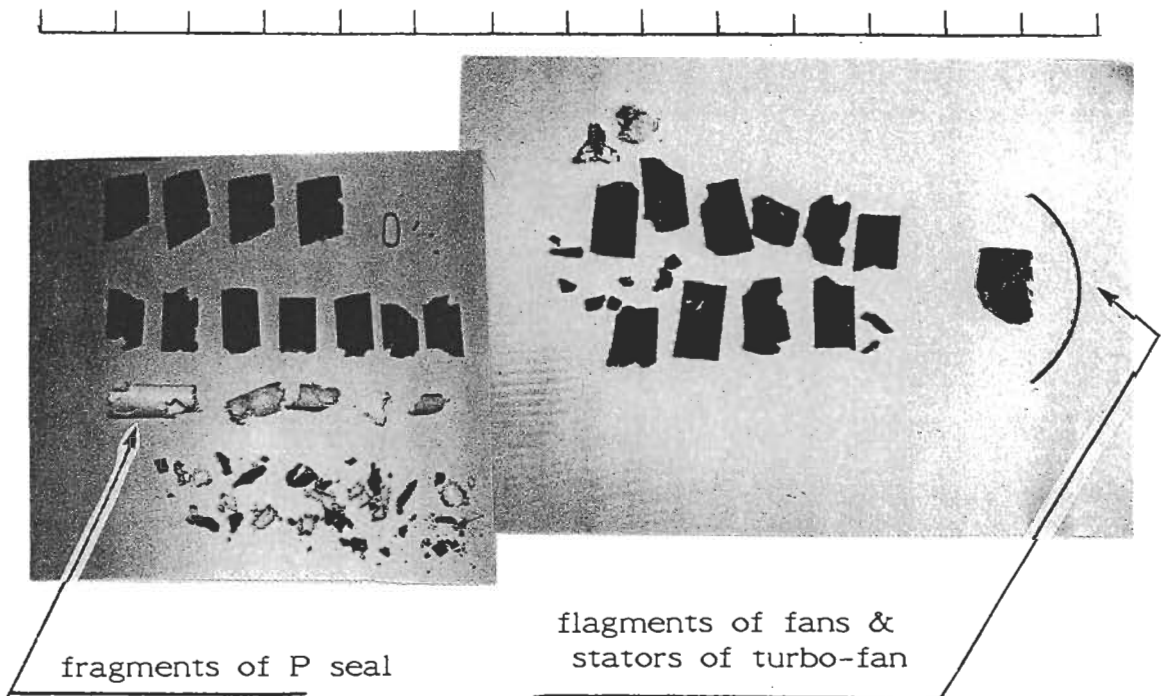

Photo. 2 Fragments of fractured Turbo-fan  
found in the upper air chamber

1 unit : 5 cm



fragments of P seal

fragments of fans &  
stators of turbo-fan

Photo. 3 APU Load Gearbox

input drive gear

cooling fan idler gear

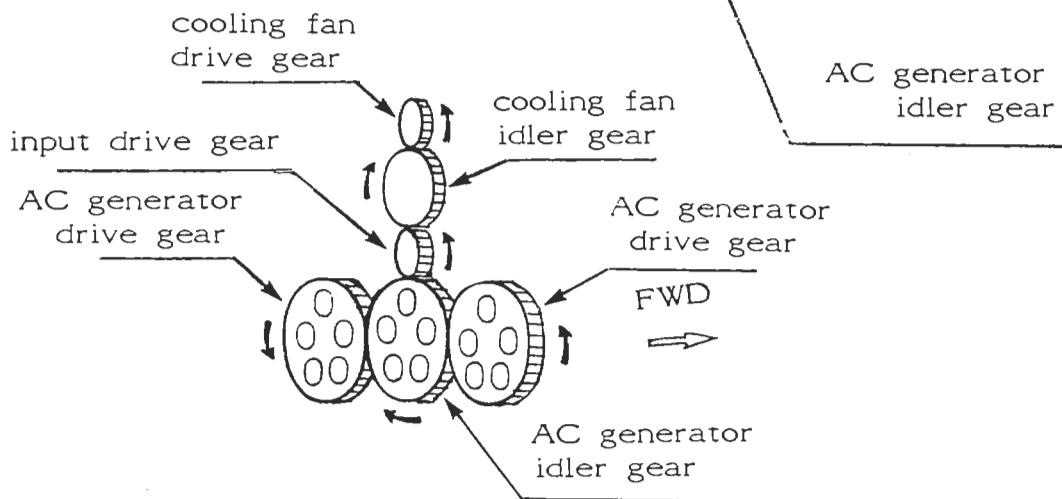
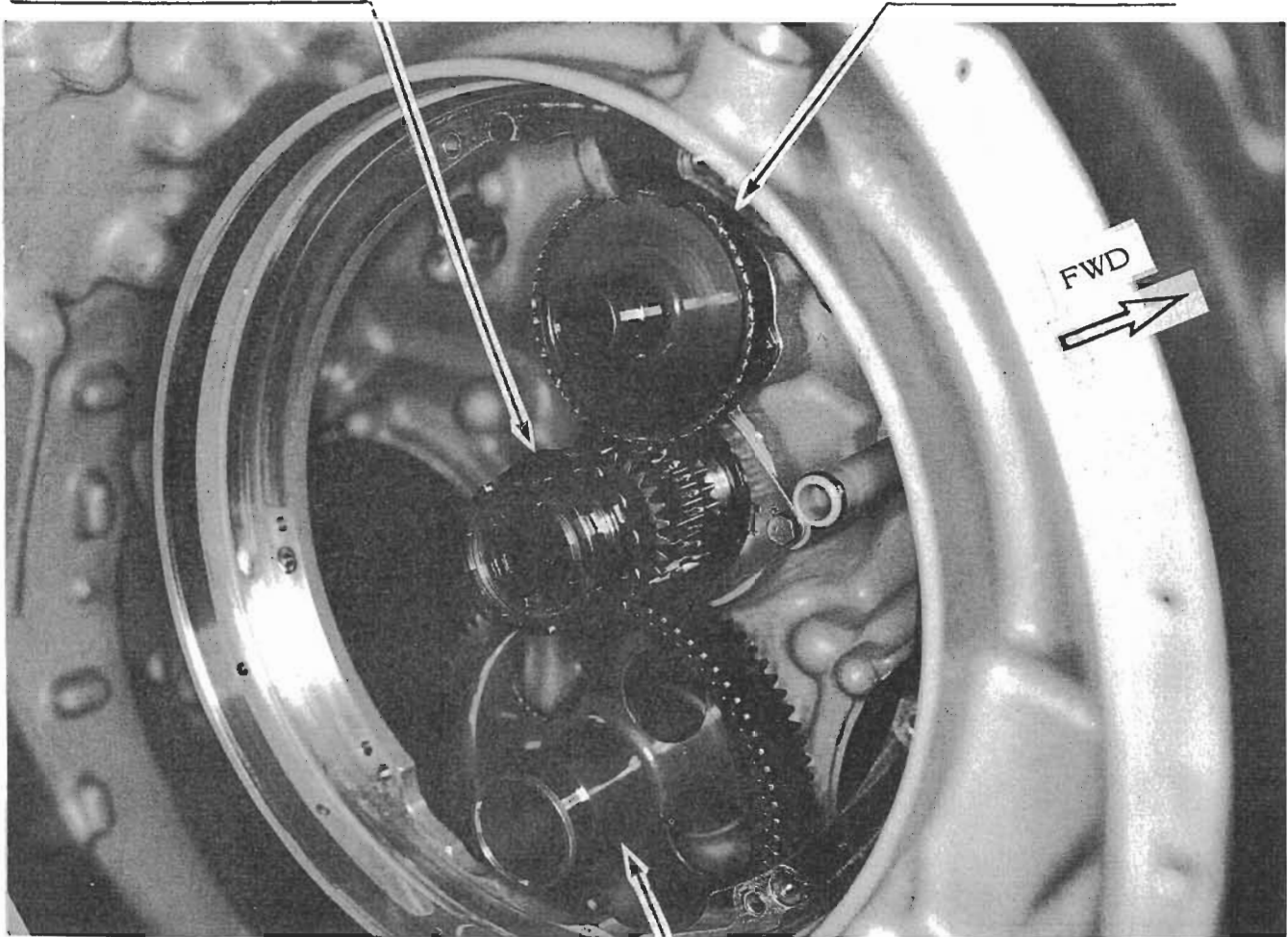
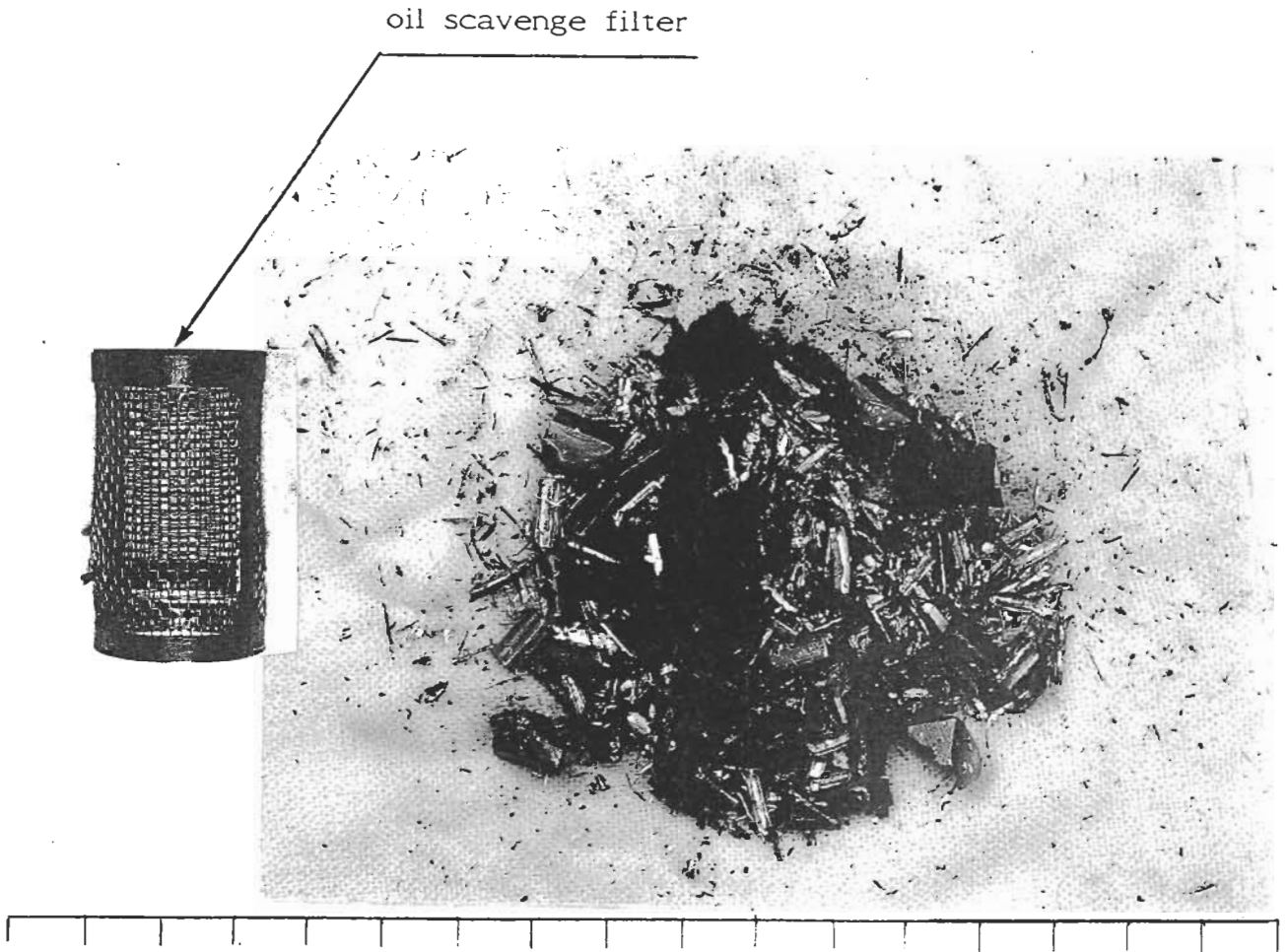



Photo. 4 Metal Fine Flakes found on Oil  
Scavenge Filter of APU Load Gearbox



1 unit : 1 cm

Photo. 5 Fractured Cooling Fan Idler Gear

↑ FWD

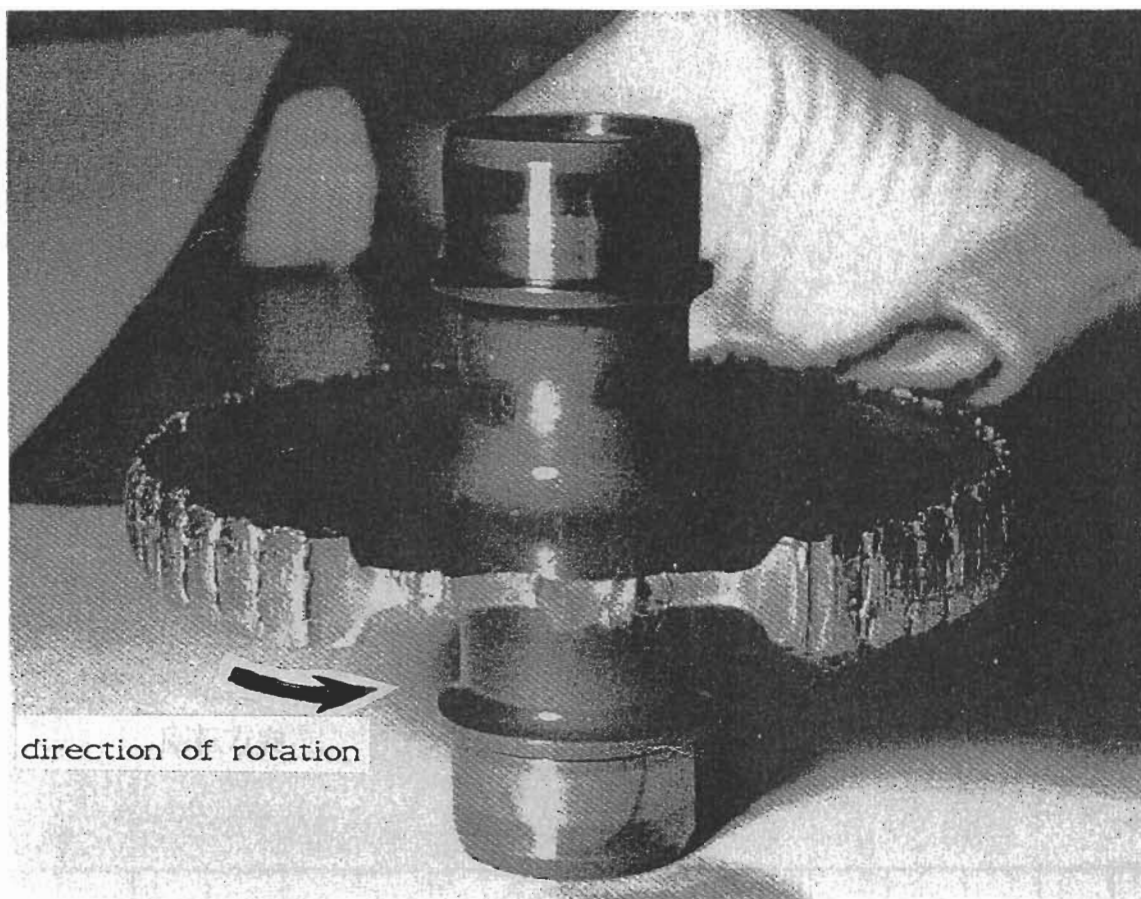

Photo. 6 Fractured Cooling Fan Drive Gear

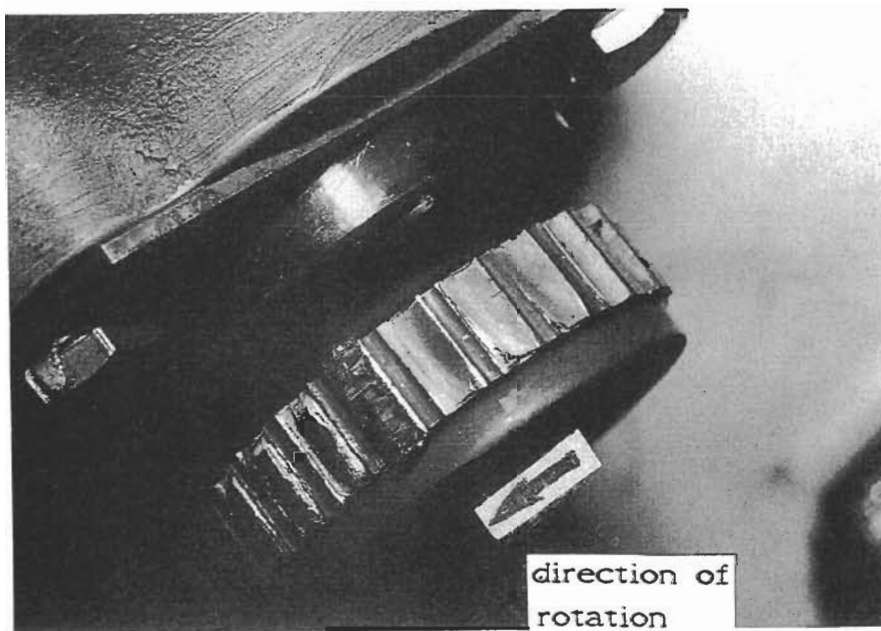
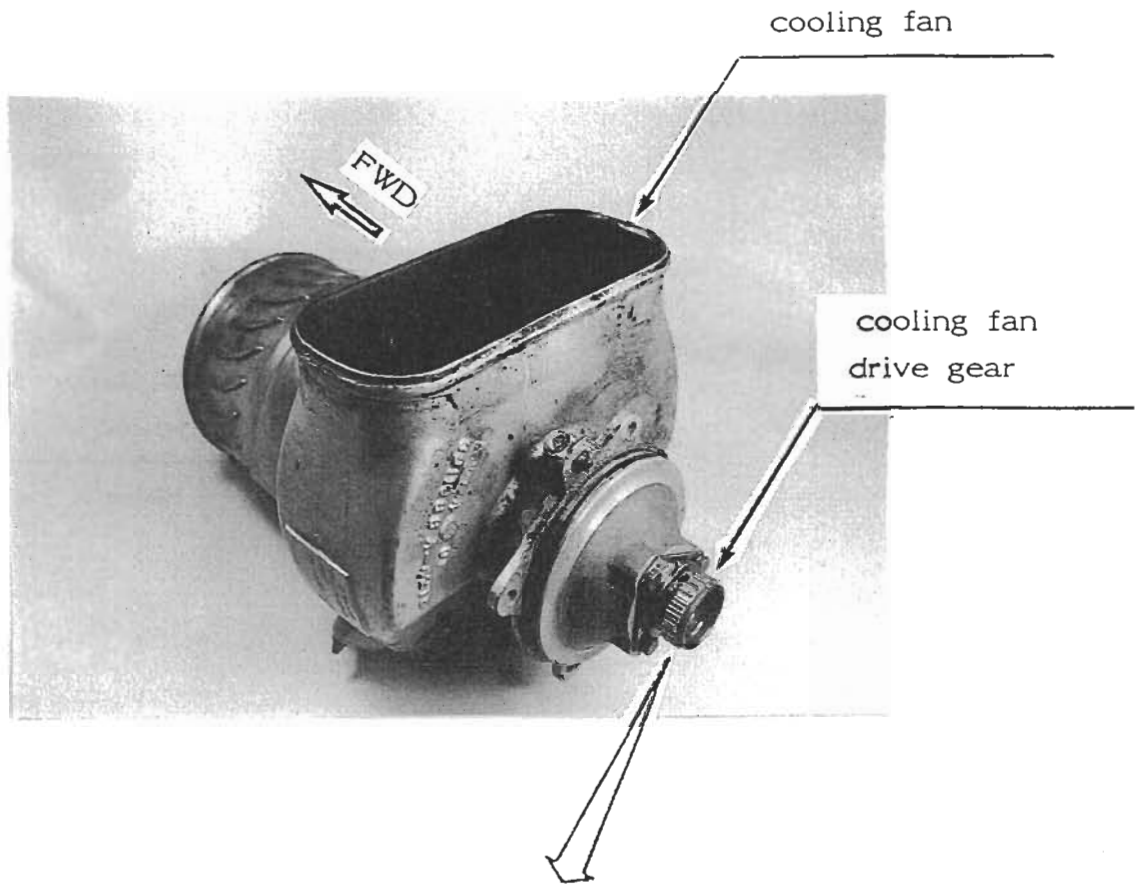

Photo. 7 No.0 Bearing Air Seal

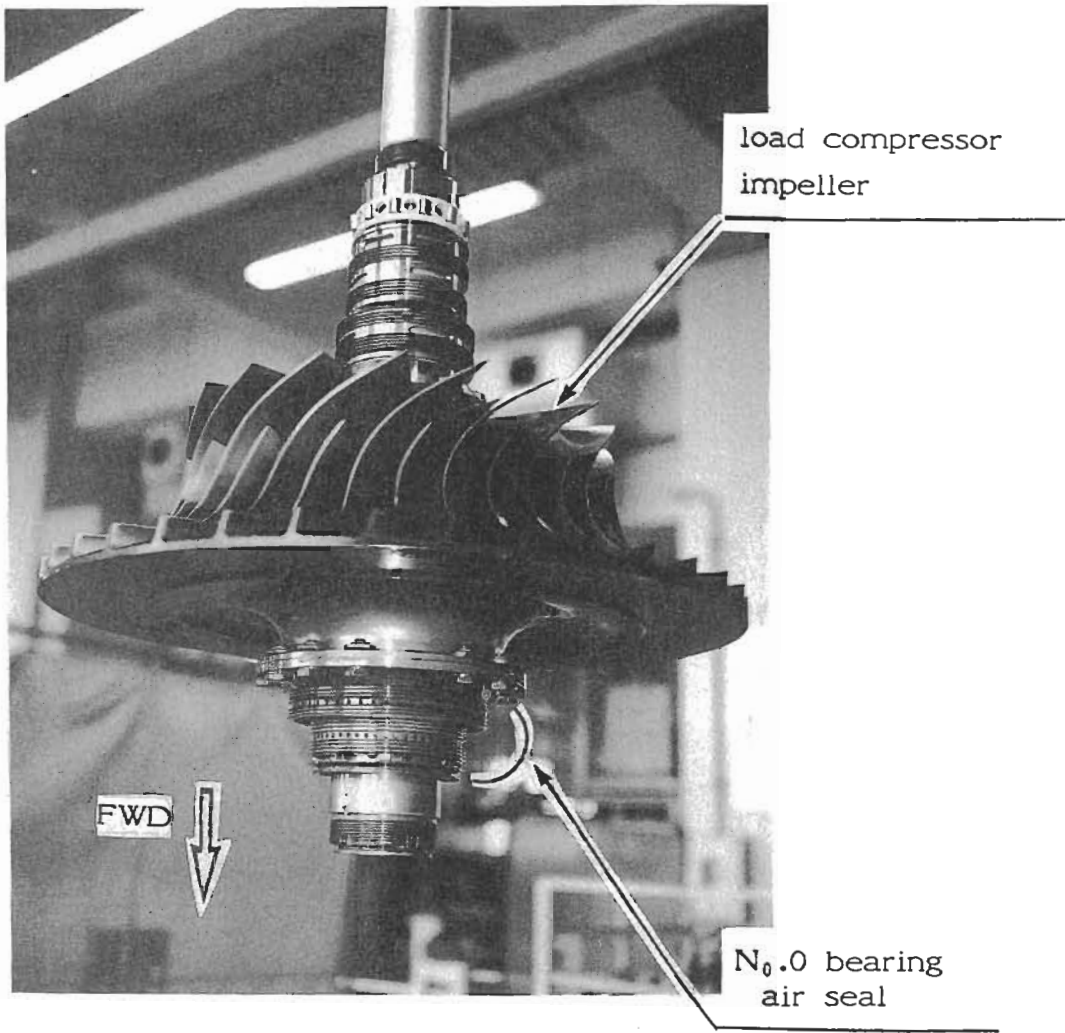
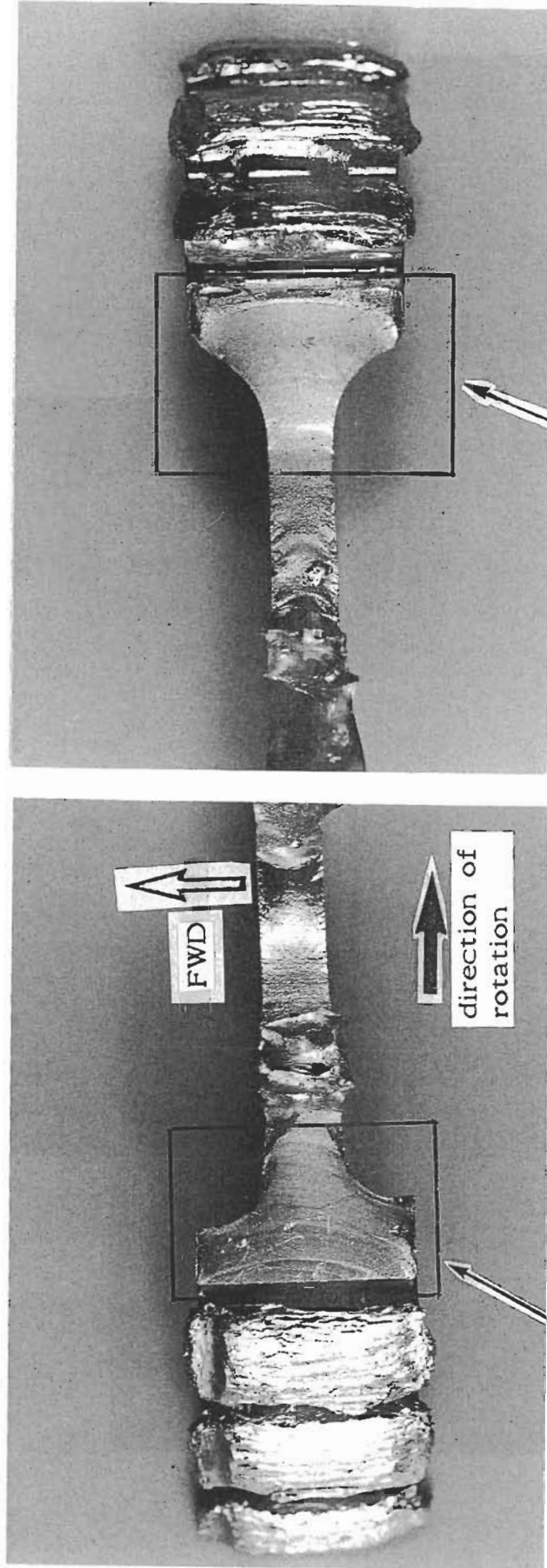

Photo. 8 Fractured Cooling  
Fan Idler Gear



see Photo.9 & Photo.10

see Photo.11 thru. Photo.13

Photo. 9 SEM View of Fractured  
Cooling Fan Idler Gear

x 20

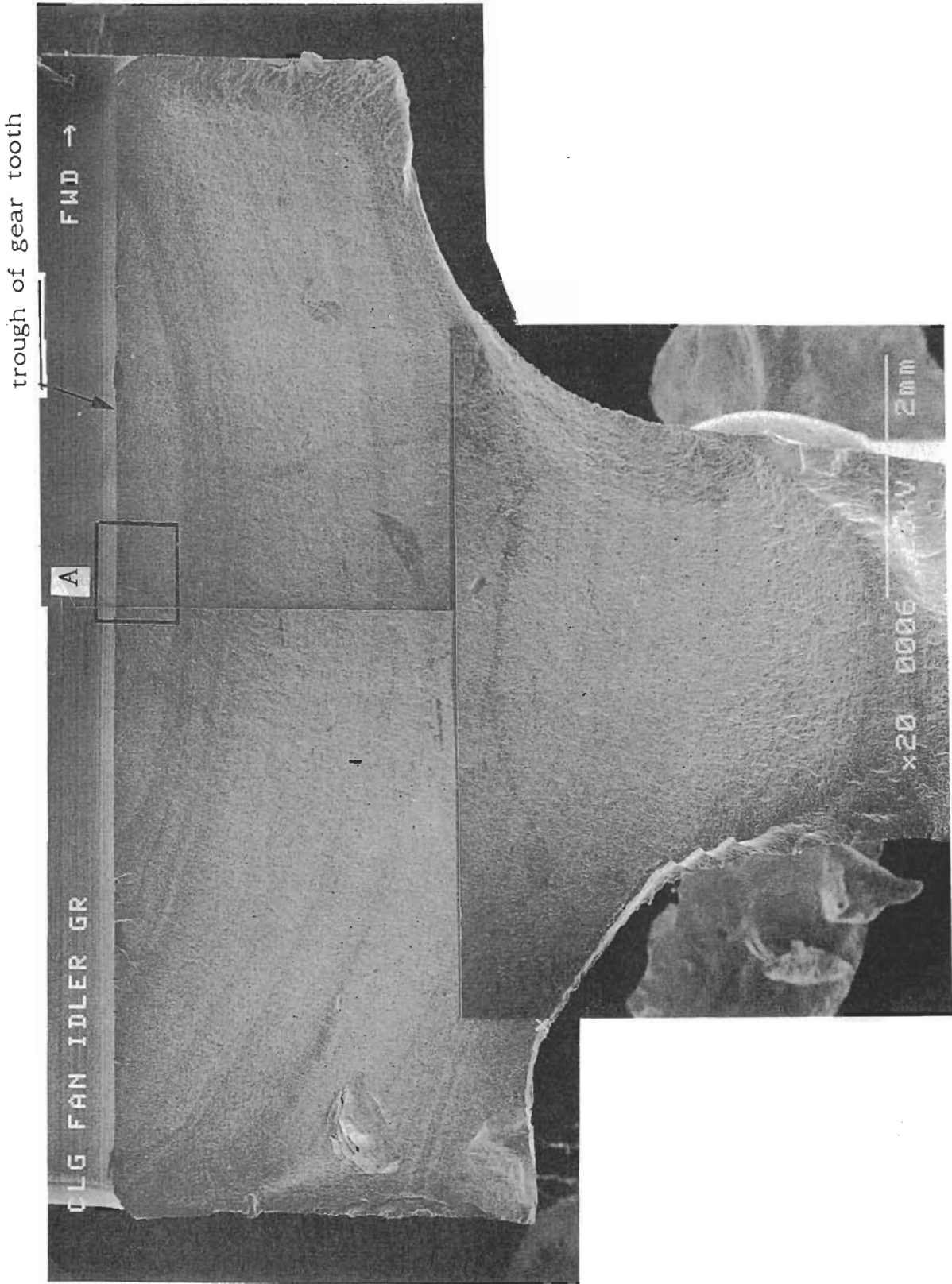
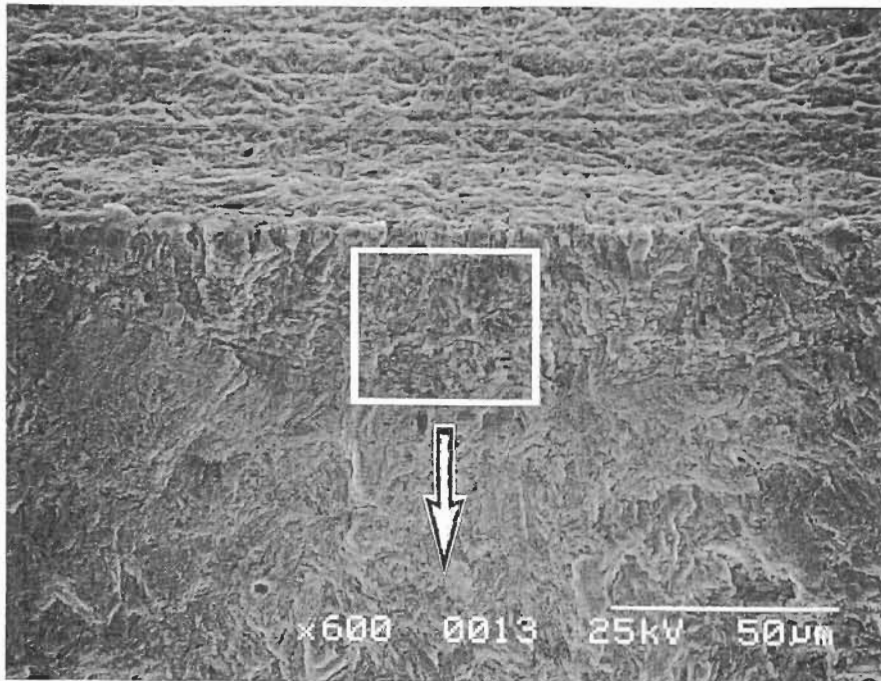
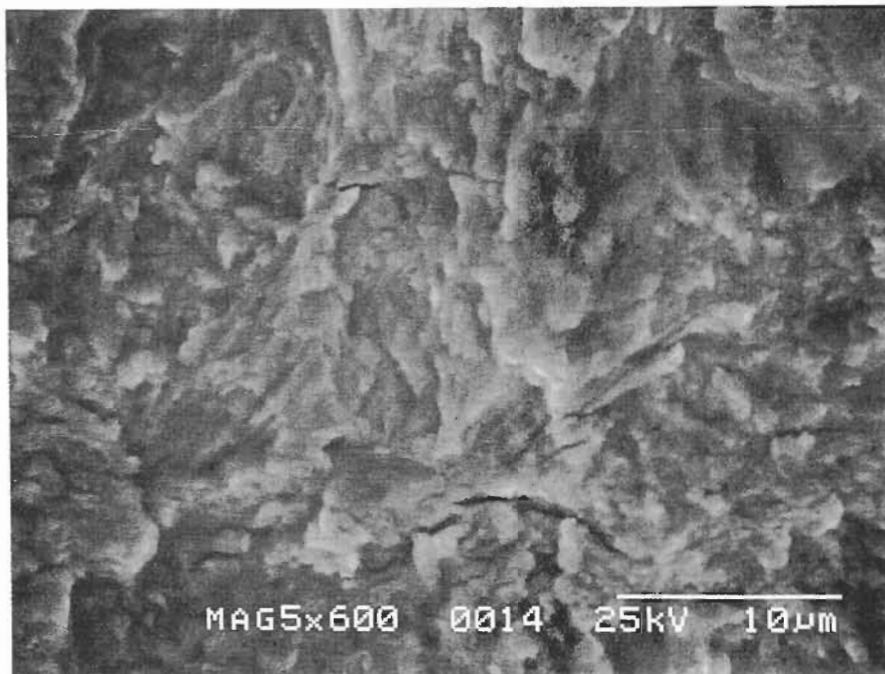

Photo.10 SEM View of Fractured Cooling Fan Idler Gear (Position A on Photo.9)



x 600



x 3,000

Photo.11 SEM View of Fractured  
Cooling Fan Idler Gear

x 20

trough of gear tooth

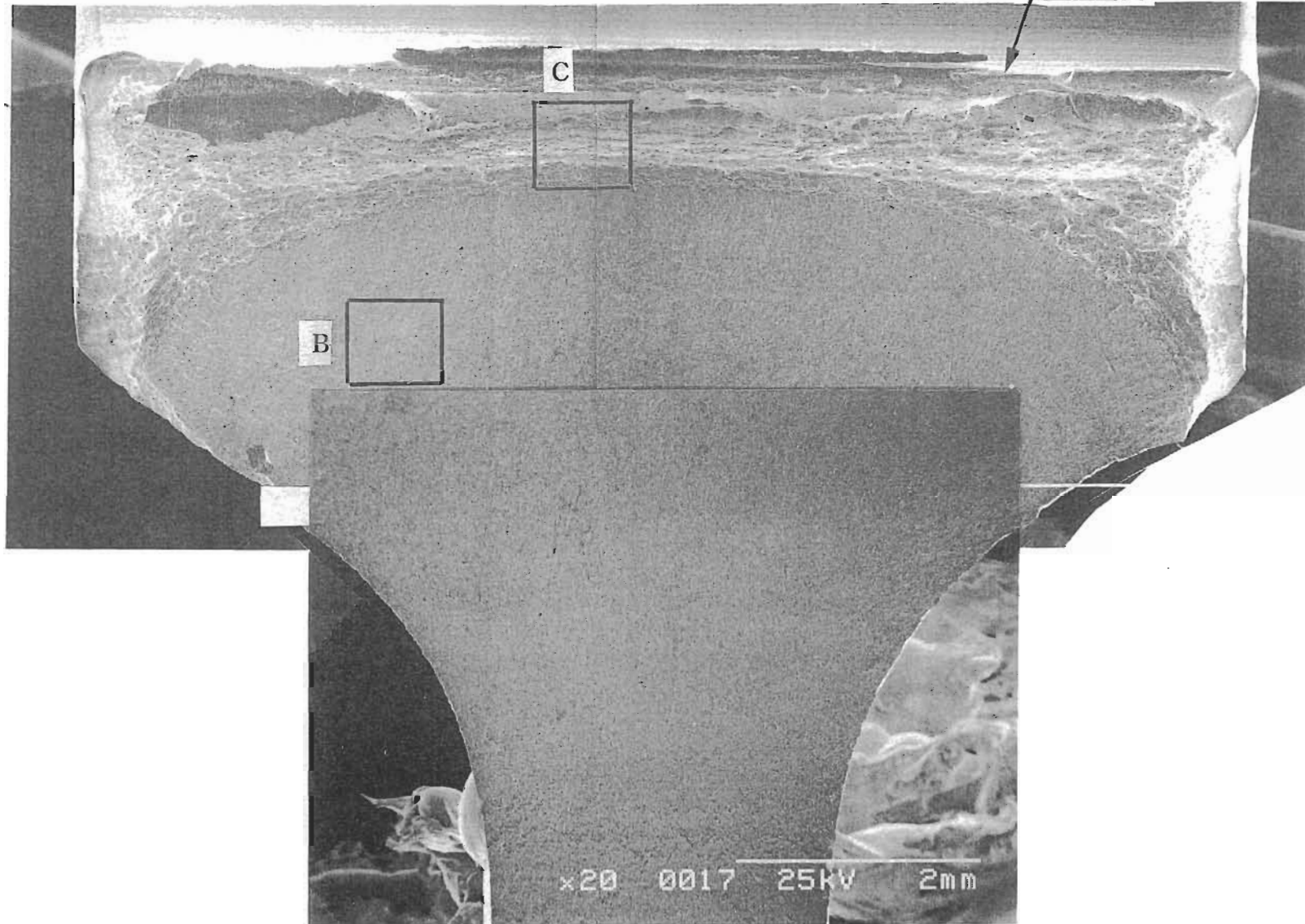
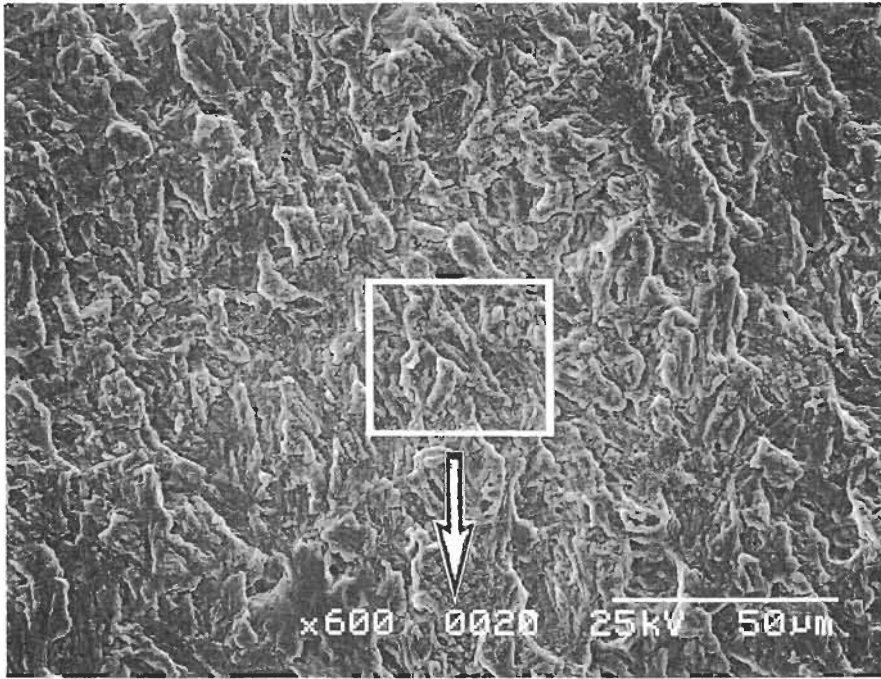

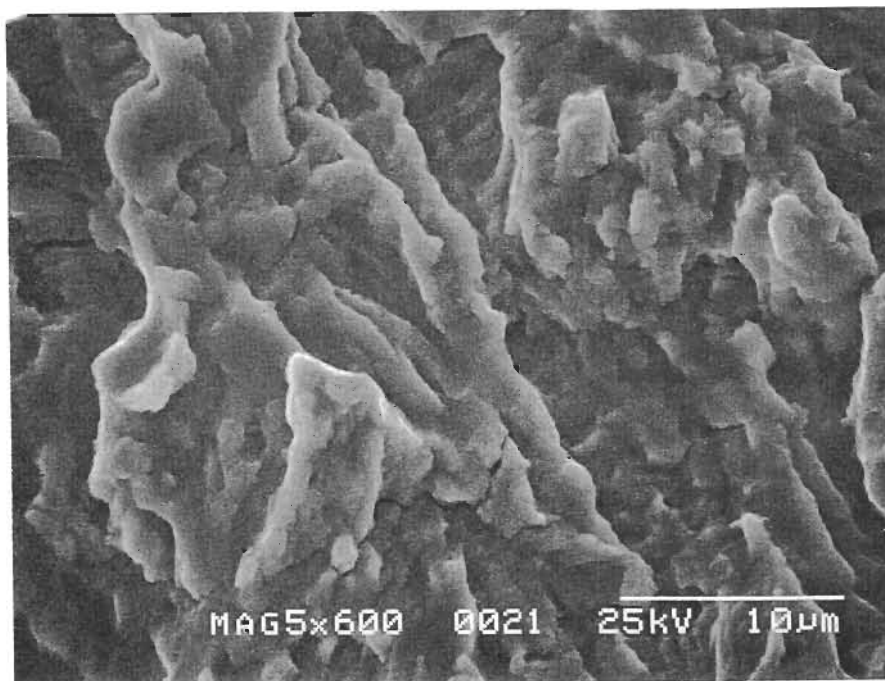

Photo.12 SEM View of Fractured Cooling Fan Idler Gear (Position B on Photo.11)



x 600

Expanded



x 3,000

Photo.13 SEM View of Fractured Cooling Fan  
Idler Gear(Position C on Photo.11)

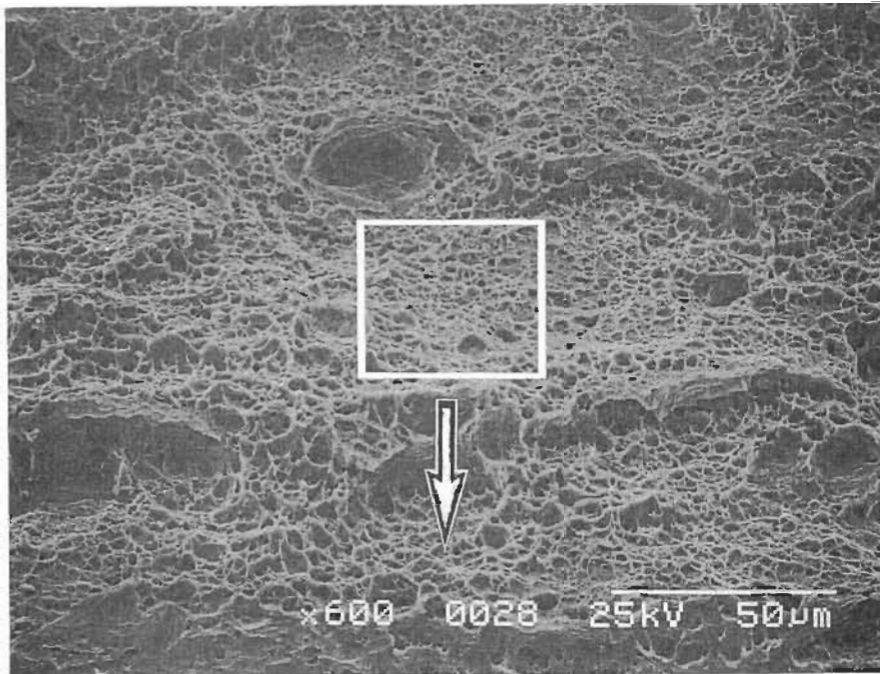

Expanded

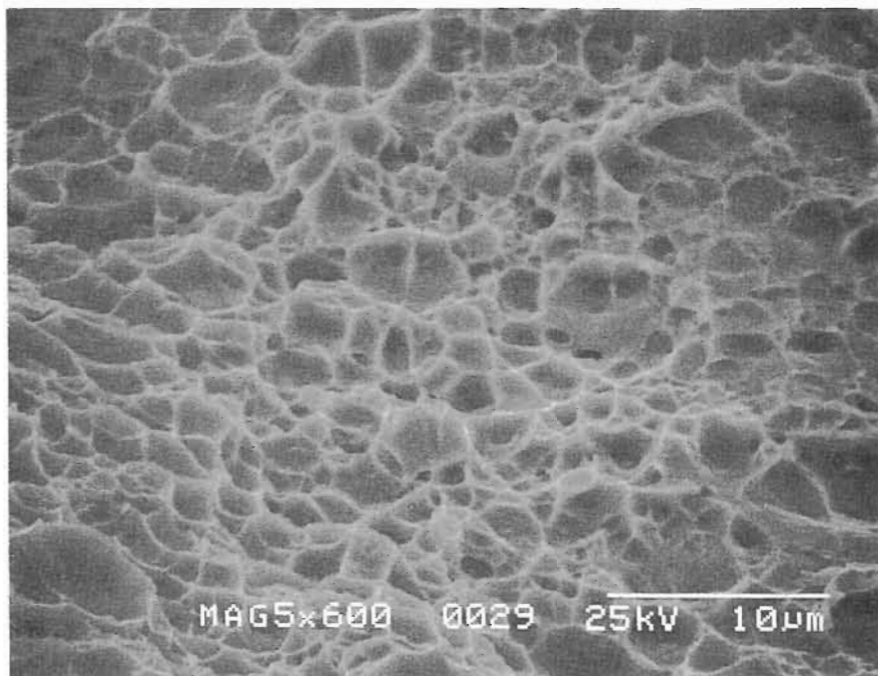
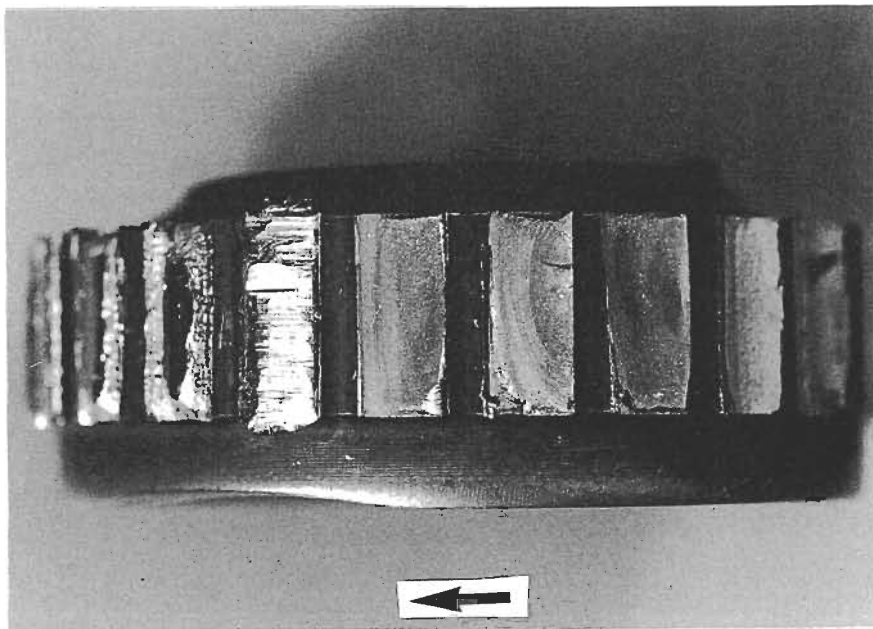

Photo.14 Fractured Cooling Fan Drive Gear



direction of rotation

